

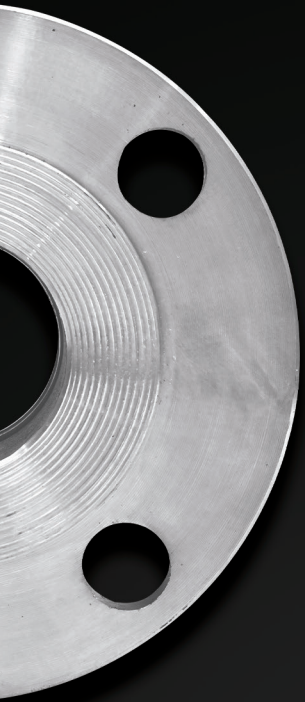

RACER[®]

RACER VALVES PRIVATE LIMITED



The Ultimate Valves
**FOR HIGH
PERFORMANCE
NEEDS**

Index

The Foundation Stone	04
Highlight	05
BALL VALVES	
I. C. Ball Valves Screw End (Single Piece Design)	06
I. C. Ball Valves Flange End (Single Piece Design)	07
I. C. Ball Valves Flange End (Two Piece Design)	08
I. C. Ball Valves Screw End (Three Piece Design)	09
I. C. Ball Valves Flange 150# & 300# End. (Three Piece Design)	10
I. C. Ball Valves Flange End E Table & F Table (Three Piece Design)	11
C. S. Ball Valves Three Piece Flange End	12
C. I. Ball Valves Three Piece Flange End	13
C. I. Ball Valves Flange End. (Two Piece Design)	14
C. I./M. S./S.S. Ball Valves Screw End (Single Piece Design)	15
C. S. Ball Valves Screw End (Three Piece Design)	16
Forged Steel Ball Valves	17
I. C. Three Way Ball Valves Screw End	18
Three Way Ball Valves Flange End	19
I. C. Flush Bottom Ball Valves	20
Jacketed Ball Valves Flange End	21
I. C. TC End Ball Valves	22
BUTTERFLY VALVES	
Butterfly Valves (PN10)	23
Butterfly Valves (PN16)	24
PTFE LINED BALL VALVES & BUTTERFLY VALVES	
PTFE Lined Ball Valves Lever Operated	25
PTFE Lined Butterfly Valves Lever Operated	26
GATE & GLOBE VALVES	
Gate Valves Flange End	27
Globe Valves Flange End	28
I. C. Gate Valves Screw End	29
I. C. Globe Valves Screw End	30
Forged Steel Gate & Globe Valves	31

CHECK VALVES (NRV)

I. C. Disc Check Valves (DCV) Non Return Valve	32
I. C. Wafer Check Valves (NRV)	33
Wafer Check Valves (NRV) (Barstock)	34
Swing Check Valves (NRV)	35
Dual Plate Check Valves (NRV)	36

INDUSTRIAL STRAINERS

I. C. "Y" Strainer Screw End	37
I. C. "Y" Strainer Flange End	38
C. I. "Y" Strainer Screw End	39
C. I. "Y" Strainer Flange End	40
C. S. "Y" Strainer Flange End	41
T/Basket/ Bucket Type Strainer Flange End 150# (Fabricated)	42

INDUSTRIAL SIGHT GLASSES

I. C. Full View Sight Glass	43
I. C. Double Window Sight Glass	44
Full View Sight Glass Barstock Type (M. S./S. S.)	45
Gauge Glass Cock Set Screw End & Gauge Glass Cock Set Flange End	46

NEEDLE VALVES

Needle Valves	47
---------------	----

STEAM TRAPS

I. C. Steam Traps	48
C. I. Bucket & Ball Float Type Steam Traps	49

OTHER INDUSTRIAL VALVES

Knife Edge Gate Valve	50
C. I. Foot Valves Flange End 150#	51

POLYPROPELENE (PP) VALVES

PP Ball Valves Flange End	52
PP Foot Valves Flange End	53
PP NRV Flange End	54
Other Products	55-57
Certificate / Client List	58
Our Achievements	59

The Foundation Stone

Since more than 42 years, Racer Valve has been a leading name in the industry. Ours is an established unit where we design and manufacture industrial valves and pipe line products. With our supreme design and high quality, we have created a niche for our products in the market. Our clients are from across the industries, be it chemicals, pharmaceuticals, petroleum, textile, sugar, paper, oil, Gas, Steam & other Fluid services. Every product is designed, manufactured and guaranteed as per international standard specification. We have the broadest range of valves available to meet the requirements of the clients across industries. The company is proud to serve the industry by offering latest innovative valves. Every valve is designed to perfection, catering to the current requirements and trends in the industry. They are designed, manufactured and distributed in accordance with requirements.

Product & Material Range

Investment Casting | C. S. | M. S. | C. I. | S. S. | Ball Valve | Gate Valve |
Globe Valve | Plug Valve | Check Valve | Sight Glass | Pulp Valve |
Butterfly Valve | Needle Valve | Guage Class Clock Set





Highlights

Since the inception, Racer Valve has been accepting new challenges and setting new benchmarks for others to follow. With innovative solutions, we have successfully acquired a leading position within the Industrial Valves Manufacturing Industry. Our mission is to focus on the efficiency of the valves, the valves, making sure that they offer maximum performance at every level. During the manufacturing process, we ensure that the design and quality of the valves is enhanced and improved. We have been continually evaluating innovative methodologies and development approaches. With the best blend of advanced technology and impressive strategy, we research and develop valve solutions for the burgeoning industrial sector. Our governance has been such designed that it remains flexible yet stays put on the ingrained standard of quality. We have been successfully meeting the challenges thrown by globally competitive environment.

Late Mr. Kishor Panchal is the name behind the beginning of the flourishing company, Racer Valve. He founded the company for developing solutions that adhere to the ever changing demands of the customers. His values and ethics still influence the functioning of the company. The core value is to understand the needs of the customers and cater to them in the best possible manner. The customer is treated with respect and care not just for first interaction but for years to come. We believe in developing long lasting relations that flourish with time. The torch of excellence lighted by him is being carried forward by his son, Mr. Nikunj Panchal. We ensure that customers are given the best experience not just through high quality products but also through time bound and cost-effective solutions and satisfying after sale services. Since the inception of the company, our motive remains to establish performance sustained presence in the industry.

Unique Features

- Positive Sealing
- No Steam Leakage
- Lower Installed Cost
- Quarter Turn Operation
- Bubble Tight Shut-Off
- Self Cleaning PTFE seats offer long life and low torque
- Seats and seals are easily replaced
- Wrench indicate valve bore direction
- Smooth cylindrical port provides excellent flow characteristics and reduces energy wasting pressure drops
- Valves are produced using the investment cast method, which offers uniform dimensions, high quality dense material and extra ordinary attractive finish
- Valves provide two-way shut off



I. C. Ball Valves Screw End

(SINGLE PIECE DESIGN)



Technical Data

Design & Manufacturing Std: BS 5351
 Testing & inspection Std: API 598 / BS 5146
 Face To Face: As Per Ansi B 16.10
 End Connections: Screw : BSP / BSPT / NPT
 Female Threading

Drawing »

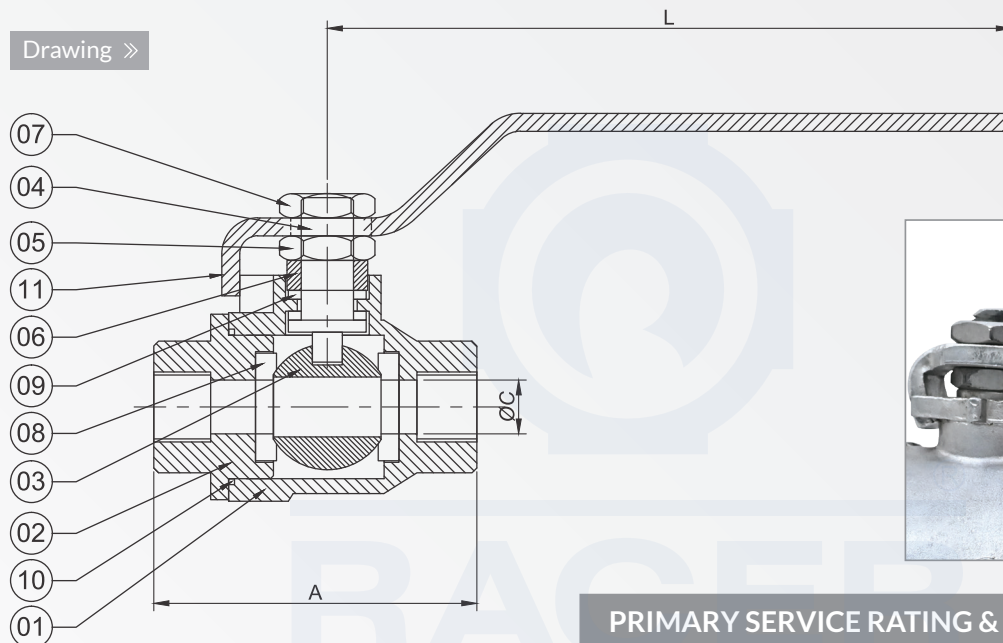

I. C. BALL VALVE 1PC S/E

Size		A	ØC	L
Inch	M.M.			
1/4"	8	53	10	115
3/8"	10	53	10	115
1/2"	15	65	12.5	115
3/4"	20	72	19	135
1"	25	83	25	134
1.1/4"	32	92	32	165
1.1/2"	40	102	38	170
2"	50	120	50	170
2.1/2"	65	144	63	290
3"	80	160	75	290
4"	100	179	100	365

PRIMARY SERVICE RATING & TEST PRESSURE

Class	Hydro Test Pressure		Max. Temp.
	Body	Seat	
150	425 PSI	300 PSI	180°C

S. N.	Parts Name	Material	Qty
01	Body	ASTM A 351 Gr. CF8/CF8M/CF3/CF3M	1
02	Body Connector	ASTM A 351 Gr. CF8/CF8M/CF3/CF3M	1
03	Ball	-Do-/AISI 304/316/304L/316L	1
04	Stem	AISI 304/316/304L/316L	1
05	Gland Nut	AISI 304/316/304L/316L	1
06	Gland Bush	AISI 202/304/316/304L/316L	2
07	Lock Nut	AISI 304/316/304L/316L	1
08	Seat Ring	PTFE/GFT	1
09	Gland Packing	PTFE/GFT	2
10	Body Sealant Ring	PTFE/GFT	1
11	Lever	S.S. 202, 304, 316 / M.S.	1

Note: (1) All Dimension are in mm.
 (2) Tolerance ± 3 mm
 (3) 65 mm and Above
 Lever Material will be MS

Application



I. C. Ball Valves Flange End

(SINGLE PIECE DESIGN)

Technical Data

Design & Manufacturing Std: BS 5351
 Testing & inspection Std: API 598 / BS 5146
 Face To Face: As Per ANSI B 16.10
 End Connections: As Per ANSI B 16.5

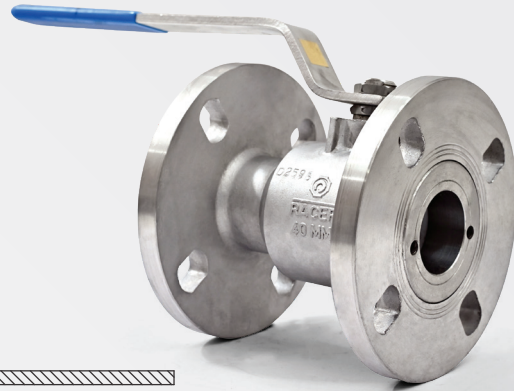

Drawing »

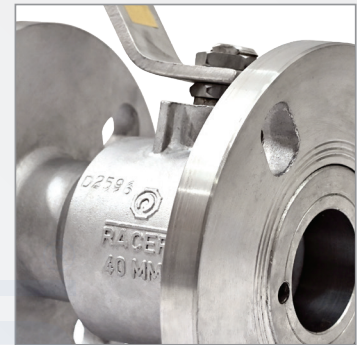
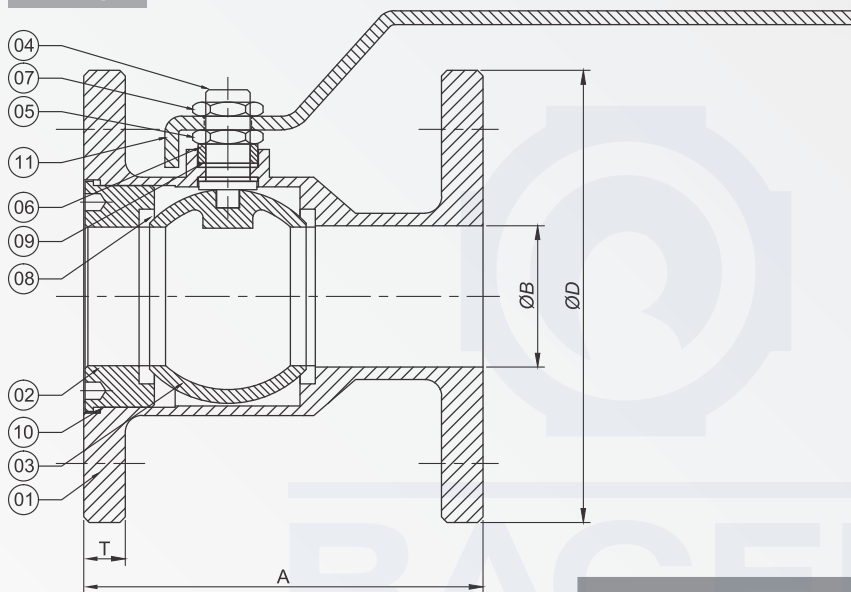

PRIMARY SERVICE RATING & TEST PRESSURE

Class	Hydro Test Pressure		Max. Temp.
	Body	Seat	
150	425 PSI	300 PSI	180°C

I. C. BALL VALVE 1PC F/E 150#

Size		A	ØD	ØB	T
Inch	M.M.				
3/4"	20	100	100	19	10
1"	25	105	118	25	10
1.1/2"	40	125	138.5	38	13
2"	50	144	163	50	14.5
2.1/2"	65	190	177	63	18
3"	80	203	191	76	18.5
4"	100	229	228	100	20

S. N.	Parts Name	Material	Qty
01	Body	ASTM A 351 Gr. CF8/CF8M/CF3/CF3M	1
02	Body Connector	ASTM A 351 Gr. CF8/CF8M/CF3/CF3M	1
03	Ball	-Do-/AISI 304/316/304L/316L	1
04	Stem	AISI 304/316/304L/316L	1
05	Gland Nut	AISI 304/316/304L/316L	1
06	Gland Bush	AISI 202/304/316/304L/316L	1
07	Lock Nut	AISI 304/316/304L/316L	1
08	Seat Ring	PTFE/GFT	2
09	Stem Seal	PTFE/GFT	2
10	Body Sealant Ring	PTFE/GFT	1
11	Lever	M.S./S.S.-202/304/316	1

Note: (1) All Dimension are in mm.
 (2) Tolerance ± 3 mm
 (3) 65 mm and Above
 Lever Material will be MS

Application



I. C. Ball Valves Flange End

(TWO PIECE DESIGN)

Technical Data

Design & Manufacturing Std: BS 5351 / API 6 D
 Testing & inspection Std: API 598 / BS 5146
 Face To Face: As per ANSI B 16.11
 End Connections: Flange as per ANSI B 16.5

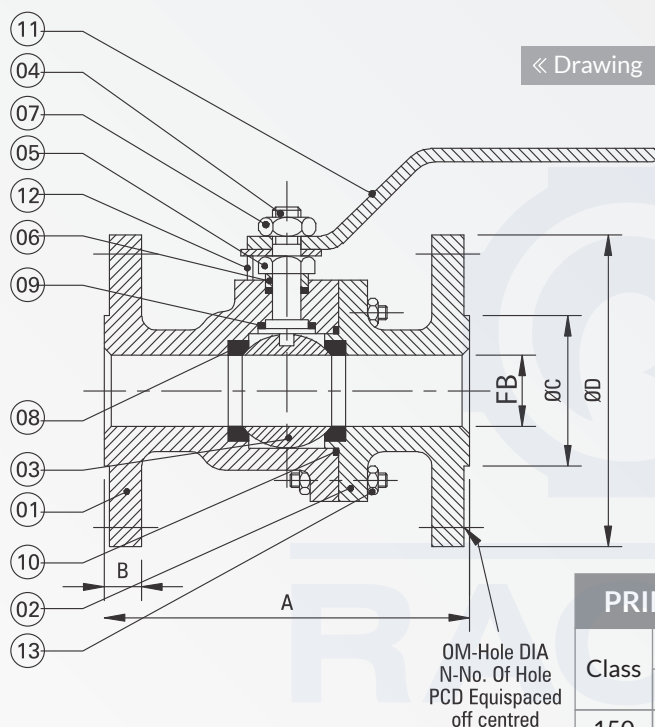
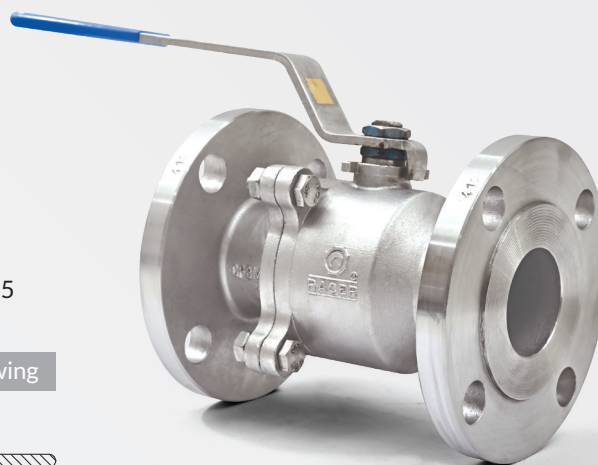

« Drawing



PRIMARY SERVICE RATING & TEST PRESSURE

Class	Hydro Test Pressure		Max. Temp.
	Body	Seat	
150	425 PSI	300 PSI	180°C
Air Test - Seat 80 PSI ± PSI			

IC BALL VALVE 2PC F/E 150#								
Size	A	FB	ØD	ØC	PCD	B	ØM	N
15	108	12.5	89	33	60.5	10	16	4
20	117	19	99	42	70	11	16	4
25	127	25	107	51	79.5	12	16	4
40	164	38	126	73	98	14.5	16	4
50	177	50	151.5	92	121	16	19	4
65	190	63	175	105	140	17.5	19	4
80	203	75	191	127	152	18	19	4
100	231	101	230	157	190.5	19	19	8
125	253	125	253	182	216	24	22	8
150	267	150	280	213	241	26	22	8

S. N.	Parts Name	Material	Qty
01	Body	ASTM A 351 Gr. CF8/CF8M/CF3/CF3M/WCB	1
02	Body Connector	ASTM A 351 Gr. CF8/CF8M/CF3/CF3M/WCB	1
03	Ball	-Do-/AISI 304/316/304L/316L	1
04	Stem	AISI 304/316/304L/316L	1
05	Gland Nut	AISI 304/316/304L/316L	1
06	Gland Bush	AISI 202/304/316/304L/316L	1
07	Lock Nut	AISI 304/316/304L/316L	1
08	Seat Ring	PTFE/GFT	2
09	Stem Seal	PTFE/GFT	2
10	Body Sealant Ring	PTFE/GFT	1
11	Lever	M. S./S. S.-202/304	1
12	Nuts & Bolt	M. S./S. S.-202/304	-

Note: (1) All Dimension are in mm.
 (2) Tolerance ± 3 mm
 (3) 65 mm and Above
 Lever Material will be MS

Application

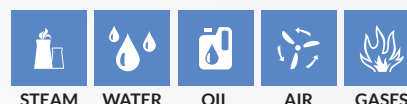

I. C. Ball Valves Screw End

(THREE PIECE DESIGN)



Technical Data

Design & Manufacturing Std: BS 5351 / API 602
 Testing & inspection Std: API 598 / BS 5146
 End Connections: BSP / NPT/Socket Weld
 Socket Weld End to: ANSI B 16.11

Drawing »

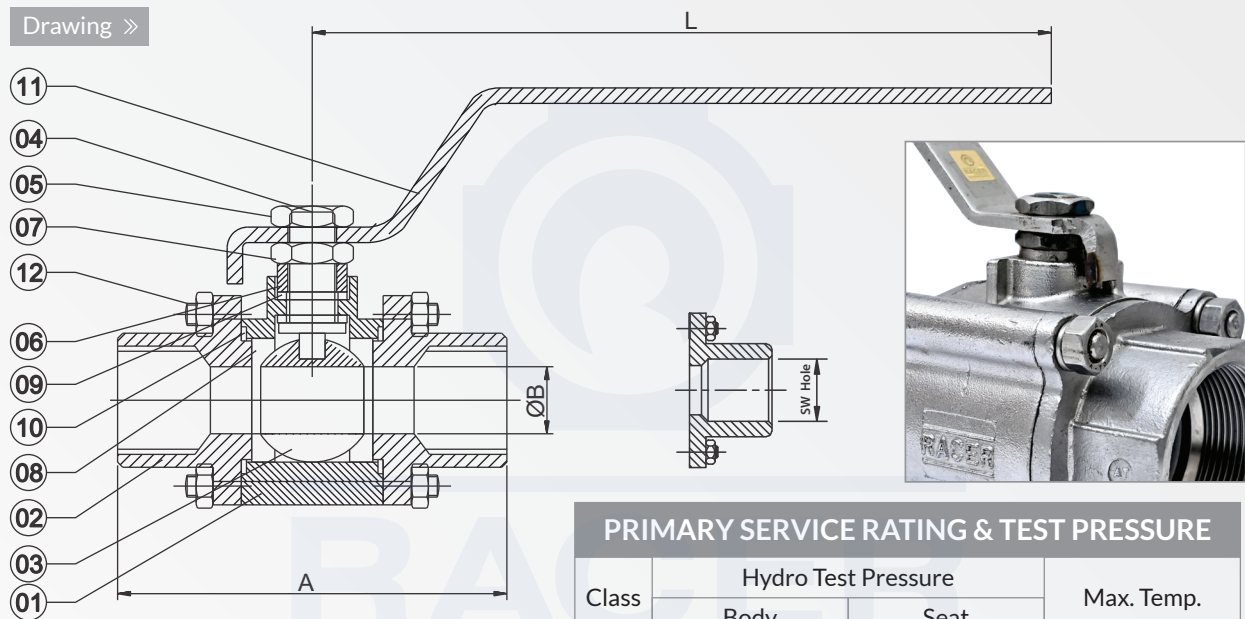

PRIMARY SERVICE RATING & TEST PRESSURE

Class	Hydro Test Pressure		Max. Temp.
	Body	Seat	
150	425 PSI	300 PSI	180°C
Air Test - Seat 80 PSI ± PSI			

I. C. BALL VALVE 3PC S/E					
Size		A	ØB	L	SOCKET WELD HOLE
Inch	M.M.				
1/2"	15	77	13	115	22
3/4"	20	81	19	135	26.5
1"	25	90	25	134	34.1
1.1/4"	32	99	32	165	43
1.1/2"	40	113	38	170	49
2"	50	132	50	170	61
2.1/2"	65	136	63	300	76
3"	80	160	75	310	89

S. N.	Parts Name	Material	Qty
01	Body	ASTM A 351 Gr. CF8/CF8M/CF3/CF3M	1
02	Body Connector	ASTM A 351 Gr. CF8/CF8M/CF3/CF3M	2
03	Ball	-Do-/AISI 304/316/304L/316L	1
04	Stem	AISI 304/316/304L/316L	1
05	Gland Nut	AISI 304/316/304L/316L	1
06	Gland Bush	AISI 202/304/316/304L/316L	1
07	Lock Nut	AISI 304/316/304L/316L	1
08	Seat Ring	PTFE/GFT	1
09	Stem Seal	PTFE/GFT	2
10	Body Sealant Ring	PTFE/GFT	2
11	Lever	M.S./S.S.-202/304/316	1
12	Nuts & Bolt	M.S./S.S.-202/304/316	-

Note: (1) All Dimension are in mm.
 (2) Tolerance ± 3 mm
 (3) Above 2" Valves we have round body designs, below that square body designs
 (4) 65 mm and Above Lever Material will be MS

Application



I. C. Ball Valves Flange End 150# & 300#

(THREE PIECE DESIGN)

Technical Data

Design & Manufacturing Std: BS 5351 / API 6 D
 Testing & inspection Std: API 598 / BS 5146
 Face To Face: As per ANSI B 16.11
 End Connections: Flange as per ANSI B 16.5

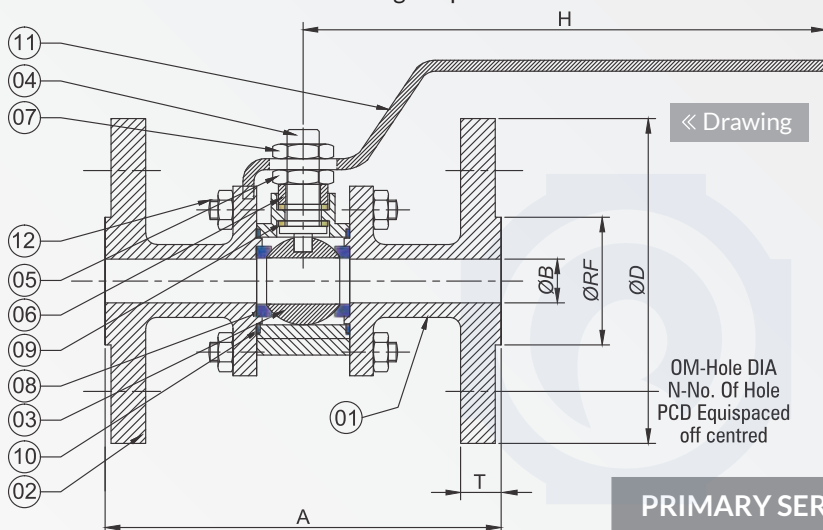
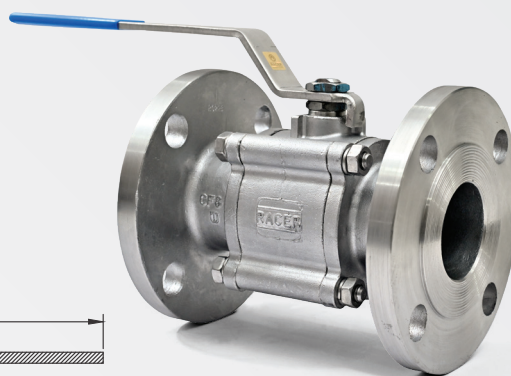

I. C. BALL VALVE 3PC F/E 300#

Size	A	ØB	ØD	T	PCD	N	ØM
25	167	25	123	17	90	4	19
40	190	38	155	21	114	4	22
50	216	50	164	23	126	8	22
65	240	63	191	25	149	8	22
80	283	75	210	29	168	8	22
100	305	100	254	32	200	8	22

I. C. BALL VALVE 3PC F/E 150#

Size	A	ØB	ØD	ØRF	PCD	T	H	ØM	N
15	109	13	87.5	35	60	11	145	16	4
20	117	19	97	43	69	11	168	16	4
25	127	25	107	51	79.5	11.5	168	16	4
32	141	32	116	63	89	14.5	168	16	4
40	165	38	126	73	98.5	14.5	255	16	4
50	178	50	151	92	121	16.5	255	19	4
65	190	64	177	105	140	17	300	19	4
80	203	76	191	127	152.5	18.5	310	19	4
100	229	101	229	157	190.5	19.5	375	19	8
125	254	125	254	186	216	23	610	22	8
150	269	150	279	216	241	25.5	610	22	8
200	293	200	343	268	298	26	870	22	8
250	335	250	409	328	361	30.5	-	26	12

PRIMARY SERVICE RATING & TEST PRESSURE

Class	Hydro Test Pressure		Max. Temp.
	Body	Seat	
150	425 PSI	300 PSI	180°C
300	1100 PSI	800 PSI	180°C

Air Test - Seat 80 PSI ± PSI

S. N.	Parts Name	Material	Qty
01	Body	ASTM A 351 Gr. CF8/CF8M/CF3/CF3M	1
02	Body Connector	ASTM A 351 Gr. CF8/CF8M/CF3/CF3M	2
03	Ball	-Do-/AISI 304/316/304L/316L	1
04	Stem	AISI 304/316/304L/316L	1
05	Gland Nut	AISI 304/316/304L/316L	1
06	Gland Bush	AISI 202/304/316/304L/316L	1
07	Lock Nut	AISI 304/316/304L/316L	1
08	Seat Ring	PTFE/GFT	2
09	Stem Seal	PTFE/GFT	2
10	Body Sealant Ring	PTFE/GFT	2
11	Lever	M.S./S.S.-202/304/316	1
12	Nuts & Bolt	M.S./S.S.-202/304/316	-

- Note: (1) All Dimension are in mm
 (2) Tolerance ± 3 mm
 (3) Above 2" Valves we have round body designs, below that square body designs
 (4) 65 mm and Above Lever Material will be MS
 (5) Also available in Gear Operated & Actuator Operated Design

Application

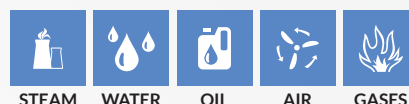

I. C. Ball Valves Flange End 'E' Table & 'F' Table

(THREE PIECE DESIGN)



Technical Data

Design & Manufacturing Std: BS 5351 / API 6 D
 Testing & inspection Std: API 598 / BS 5146
 Face To Face: As per ANSI B 16.11
 End Connections: Flange as per ANSI B 16.5

Drawing »

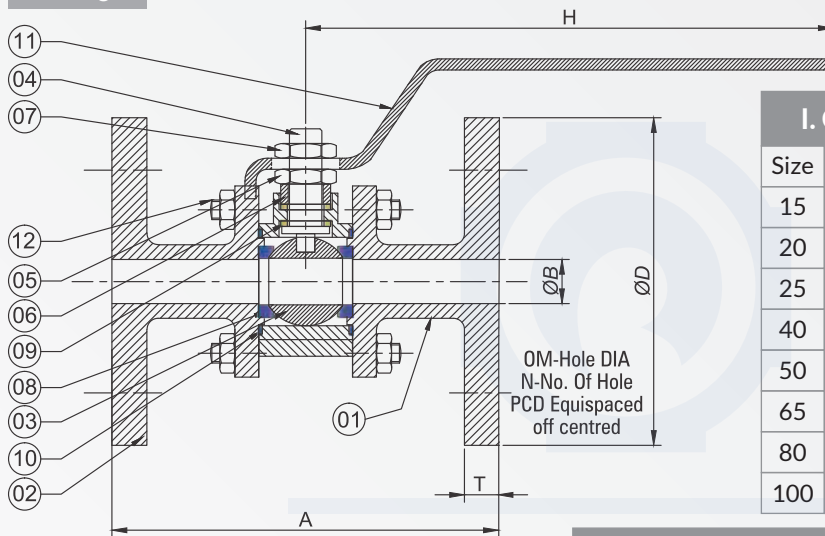

I. C. BALL VALVE 3PC E TABLE							
Size	A	ØB	ØD	T	PCD	N	ØM
15	110	12.5	95	9.5	66	4	14.5
20	120	19	102	9.5	72.5	4	14.5
25	127	25	114	9.5	82.5	4	14.5
40	165	38	131	13	98.5	4	14.5
50	178	50	150	14.5	114.5	4	17.5
65	190	64	164	14.5	126	4	17.5
80	203	76	184	14.5	145	4	17.5
100	228	100	215	17.5	177	8	19

I. C. BALL VALVE 3PC F TABLE							
Size	A	ØB	ØD	T	PCD	N	ØM
15	110	12.5	95	9.5	66	4	14.5
20	120	19	102	9.5	72.5	4	14.5
25	129	25	120	9.5	87	4	17.5
40	165	38	139	13	104.5	4	17.5
50	175	50	164	15	127	4	17.5
65	191	64	183	15	145	8	17.5
80	203	76	203	15	166	8	19
100	225	100	226	17	189	8	19

PRIMARY SERVICE RATING & TEST PRESSURE			
Class	Hydro Test Pressure		Max. Temp.
	Body	Seat	
150	425 PSI	300 PSI	180°C
Air Test - Seat 80 PSI ± PSI			

S. N.	Parts Name	Material	Qty
01	Body	ASTM A 351 Gr. CF8/CF8M/CF3/CF3M	1
02	Body Connector	ASTM A 351 Gr. CF8/CF8M/CF3/CF3M	2
03	Ball	-Do-/AISI 304/316/304L/316L	1
04	Stem	AISI 304/316/304L/316L	1
05	Gland Nut	AISI 304/316/304L/316L	1
06	Gland Bush	AISI 202/304/316/304L/316L	1
07	Lock Nut	AISI 304/316/304L/316L	1
08	Seat Ring	PTFE/GFT	2
09	Stem Seal	PTFE/GFT	2
10	Body Sealant Ring	PTFE/GFT	2
11	Lever	M.S./S.S.-202/304/316	1
12	Nuts & Bolt	M.S./S.S.-202/304/316	-

Note: (1) All Dimension are in mm
 (2) Tolerance ± 3 mm
 (3) Above 2" Valves we have round body designs, below that square body designs
 (3) 65 mm and Above Lever Material will be MS
 (5) Also available in Gear Operated & Actuator Operated Design

Application



Cast Steel Ball Valves

Flange End

(THREE PIECE DESIGN)

Technical Data

Design & Manufacturing Std: BS 5351 / API 6 D
 Testing & inspection Std: API 598 / BS 5146
 Face To Face: As per ANSI B 16.11
 End Connections: Flange as per ANSI B 16.5

« Drawing

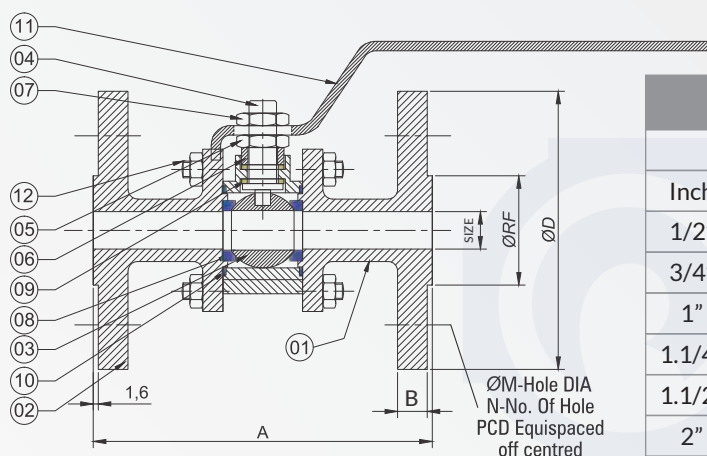

CLASS 150#

Size		A	B	ØRF	ØD	ØM	N	PCD
Inch	M.M.							
1/2"	15	108	10.0	35	89	16	4	60.4
3/4"	20	118	10.5	43	98	16	4	69.8
1"	25	127	11.0	51	108	16	4	79.2
1.1/4"	32	140	12.7	64	117	16	4	88.9
1.1/2"	40	165	14.2	73	127	16	4	98.5
2"	50	178	15.7	92	152	19	4	120.6
2.1/2"	65	191	17.5	105	178	19	4	139.7
3"	80	203	19.0	127	190	19	4	152.4
4"	100	229	24.0	157	229	19	8	190.5
5"	125	254	24.0	186	254	22	8	215.9
6"	150	267	25.5	216	277	22	8	241.3
8"	200	292	29	270	343	22	8	298.4
10"	250	330	30.5	324	406.5	22.5	12	362

PRIMARY SERVICE RATING & TEST PRESSURE

Class	Hydro Test Pressure		Max. Temp.
	Body	Seat	
150	425 PSI	300 PSI	180°C
300	1100 PSI	800 PSI	180°C

Air Test - Seat 80 PSI ± PSI

S. N.	Parts Name	Material	Qty
01	Body	C.S. (ASTM A 216 Gr. WCB)	1
02	Body Connector	C.S. (ASTM A 216 Gr. WCB)	2
03	Ball	S.S. 202/304/316	1
04	Stem	S.S. 202/304/316	1
05	Gland Nut	M.S/S.S. 202/304/316	1
06	Gland Bush	M.S/S.S. 202/304/316	1
07	Lock Nut	M.S/S.S. 202/304/316	1
08	Seat Ring	PTFE/GFT	2
09	Stem Seal	PTFE/GFT	2
10	Body Sealant Ring	PTFE/GFT	2
11	Lever	M.S.	1
12	Stud & Nuts	M.S.	-

CLASS 300#

Size		A	B	ØC	ØD	ØM	N	PCD
Inch	M.M.							
1/2"	15	140.0	14.2	35	95.0	16	4	66.5
3/4"	20	152.0	15.7	43	117.0	19	4	82.5
1"	25	165.0	17.5	51	124.0	19	4	88.9
1.1/4"	32	178.0	19.0	64	133.0	19	4	98.5
1.1/2"	40	190.5	20.5	73	155.0	22	4	114.3
2"	50	216.0	22.0	92	165.0	19	8	127.0
2.1/2"	65	241.0	25.0	105	190.5	22	8	149.3
3"	80	282.5	28.5	127	209.5	22	8	168.0
4"	100	305.0	32.0	157	254.0	22	8	200.0

Note: (1) All Dimension are in mm (2) Tolerance ± 3 mm (3) Also available in Gear Operated & Actuator Operated Design (4) Fire safe and Antistatic design available on request

(5) 10" valve will have gear operation
 (6) 12" valve also available on request

Application



Cast Iron Ball Valves Flange End

(THREE PIECE DESIGN)



Technical Data

Design & Manufacturing Std: BS 5351 / API 6 D
 Testing & inspection Std: API 598 / BS 5146
 Face To Face: As per ANSI B 16.11
 End Connections: Flange as per ANSI B 16.5

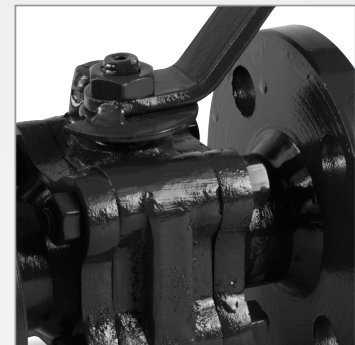
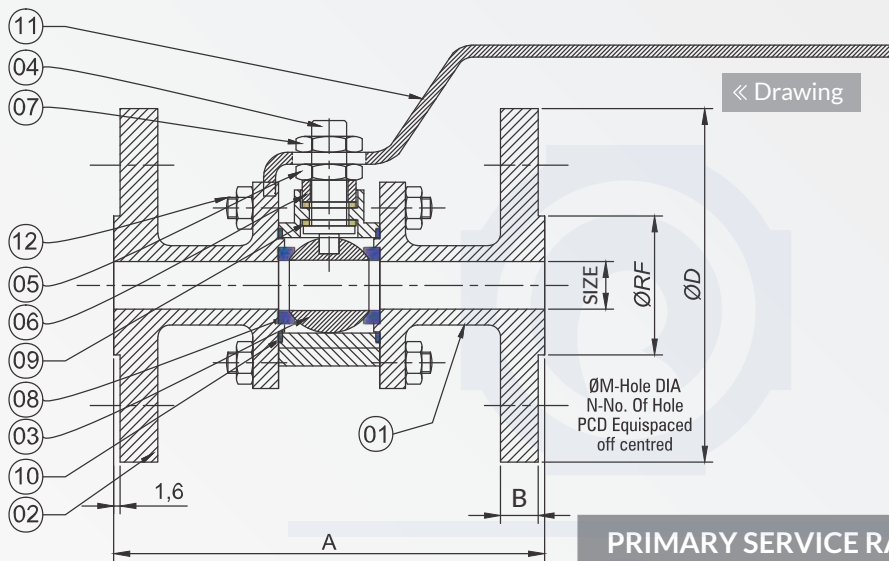

PRIMARY SERVICE RATING & TEST PRESSURE

Class	Hydro Test Pressure		Max. Temp.
	Body	Seat	
150	215 PSI	145 PSI	180°C

CLASS 150#							
Size	A	B	ØRF	ØD	ØM	N	PCD
Inch M.M.							
1/2"	15	108	10.0	35	89	16	4 60.4
3/4"	20	118	10.5	43	98	16	4 69.8
1"	25	127	11.0	51	108	16	4 79.2
1 1/4"	32	140	12.7	64	117	16	4 88.9
1 1/2"	40	165	14.2	73	127	16	4 98.5
2"	50	178	15.7	92	152	19	4 120.6
2 1/2"	65	191	17.5	105	178	19	4 139.7
3"	80	203	19.0	127	190	19	4 152.4
4"	100	229	24.0	157	229	19	8 190.5
6"	150	267	25.5	216	279	22	8 241.3
8"	200	292	29	270	343	22	8 298.4

S. N.	Parts Name	Material	Qty
01	Body	C. I.	1
02	Body Connector	C. I.	2
03	Ball	S.S. 202/304/316	1
04	Stem	S.S. 202/304/316	1
05	Gland Nut	M.S./S.S. 202/304/316	1
06	Gland Bush	M.S./S.S. 202/304/316	1
07	Lock Nut	M.S./S.S. 202/304/316	1
08	Seat Ring	PTFE	2
09	Stem Seal	PTFE	2
10	Body Sealant Ring	PTFE	1
11	Lever	M.S.	1
12	Stopper Pin	M.S.	1
13	Studs & Nuts	M.S.	-

Note: (1) All Dimension are in mm
 (2) Tolerance ± 3 mm
 (3) Square body design - upto 3",
 Round body design - 4" & above
 (4) 'E' / 'F' table also available

Cast Iron Ball Valves Flange End

(TWO PIECE DESIGN)

Technical Data

Design & Manufacturing Std: BS 5351 / API 6 D
 Testing & inspection Std: API 598 / BS 5146
 Face To Face: As per ANSI B 16.11
 End Connections: Flange as per ANSI B 16.5

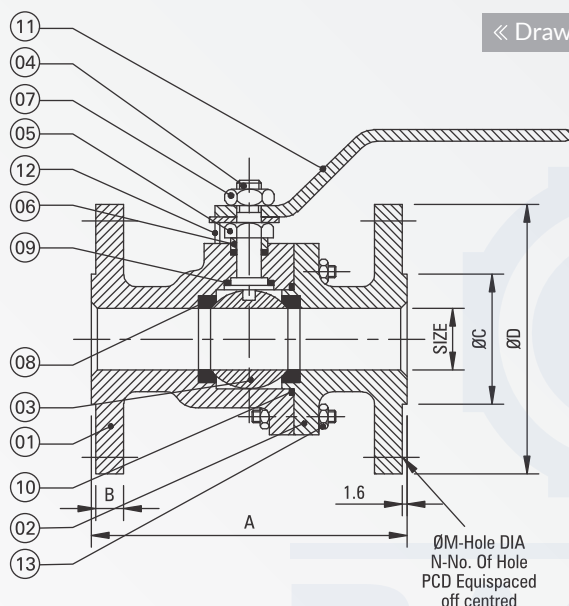
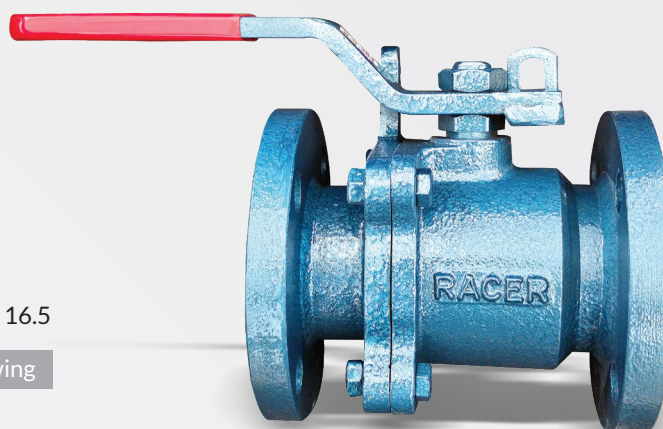

« Drawing



PRIMARY SERVICE RATING & TEST PRESSURE

Class	Hydro Test Pressure		Max. Temp.
	Body	Seat	
150	215 PSI	145 PSI	180°C

C. I. BALL VALVE 2PC F/E							
Size Inch M.M.	A	B	ØC	ØD	ØM	N	PCD
	1"	25	127	11.0	51	108	16
1.1/2"	40	165	14.2	73	127	16	4 98.5
2"	50	178	15.7	92	152	19	4 120.6
2.1/2"	65	191	17.5	105	178	19	4 139.7
3"	80	203	19.0	127	190	19	4 152.4
4"	100	229	24.0	157	229	19	8 190.5

S. N.	Parts Name	Material	Qty
01	Body	C.I.	1
02	Body Connector	C.I.	1
03	Ball	SS 202/304/316	1
04	Stem	SS 202/304/316	1
05	Gland Nut	M.S/SS 202/304/316	1
06	Gland Bush	M.S/SS 202/304/316	1
07	Lock Nut	M.S/SS 202/304/316	1
08	Seat Ring	PTFE	2
09	Stem Seal	PTFE	2
10	Body Sealant Ring	PTFE	1
11	Lever	M.S.	1
12	Stopper Pin	M.S.	1
13	Studs & Nuts	M.S.	-

Note: (1) All Dimension are in mm
 (2) Tolerance ± 3 mm
 (3) Also available with locking lever

C. I. / M. S. / S. S. Ball Valves Screw End.

(SINGLE PIECE DESIGN)

Technical Data

Design & Manufacturing Std: BS 5351
 Testing & Inspection Std: API 598
 Face To Face: As per ANSI B 16.10
 End Connections: Screw BSP / NPT

Drawing »

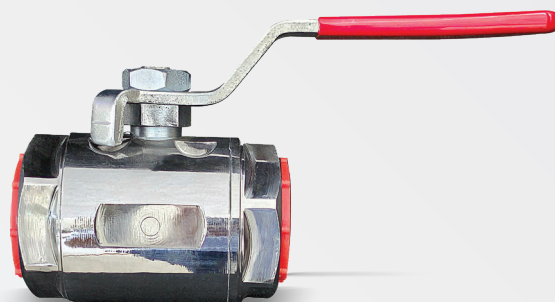
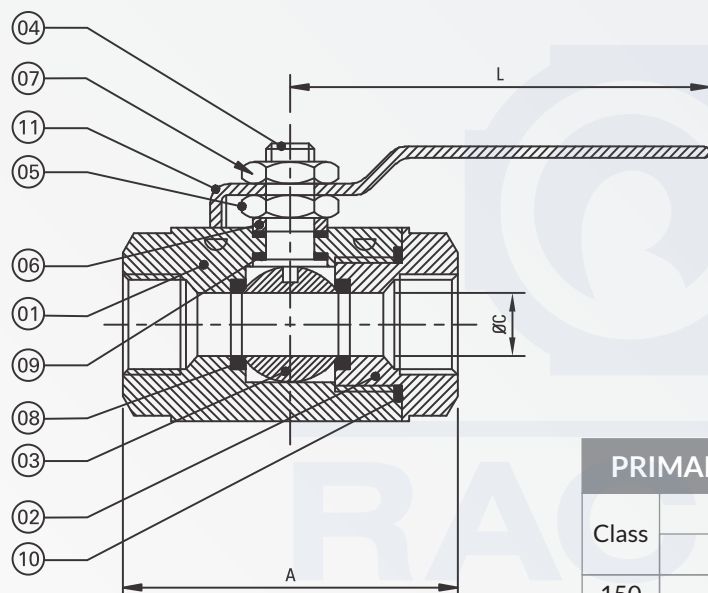

BALL VALVE 1PC S/E

Inch	M.M.	A	ØC	L
1/4"	8	052	10	110
3/8"	10	052	10	110
1/2"	15	065	13	125
3/4"	20	076	18	125
1"	25	085	25	125
1.1/4"	32	100	32	175
1.1/2"	40	100	38	175
2"	50	120	50	175
2.1/2"	65	151	63	252
3"	80	171	75	252
4"	100	180	98	252

PRIMARY SERVICE RATING & TEST PRESSURE

Class	Hydro Test Pressure		Max. Temp.
	Body	Seat	
150	425 PSI	300 PSI	180°C
Air Test - Seat 80 PSI ± PSI			

Sr. No.	Parts Name	Material	Qty
01	Body	M.S./C.I./S.S. 202/304/316	1
02	Body Connector	M.S./C.I./S.S. 202/304/316	1
03	Ball	S.S. 202/304/316	1
04	Stem	S.S. 202/304/316	1
05	Gland Nut	S.S. 202/304/316/M.S.	1
06	Gland Bush	S.S. 202/304/316/M.S.	1
07	Lock Nut	S.S. 202/304/316/M.S.	1
08	Seat Ring	PTFE/GFT	2
09	Stem Seal	PTFE	2
10	Body Sealant Ring	PTFE	1
11	Lever	M.S./S.S. 304/S.S. 316	1

Note: (1) All Dimension are in mm.
 (2) Tolerance ± 3 mm
 (3) For C.I. / M.S. / S.S. dimensions are different



C. S. Ball Valves Screw End (THREE PIECE DESIGN)

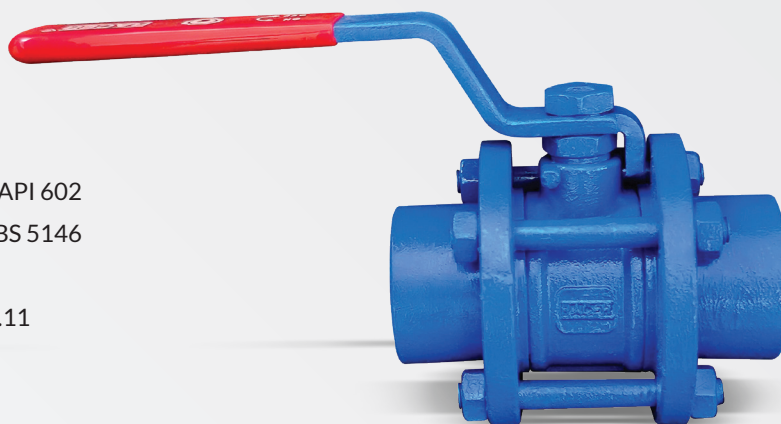

Technical Data

Design & Manufacturing Std:	BS 5351 / API 602
Testing & Inspection Std:	API 598 / BS 5146
End Connections: Screw	BSP / NPT
Socket Weld Ends to:	ANSI B 16.11

Drawing »

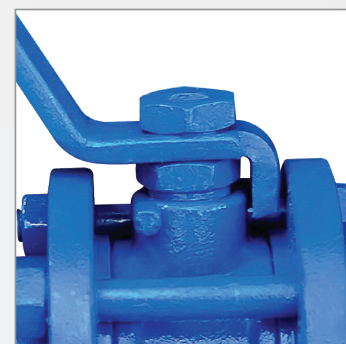
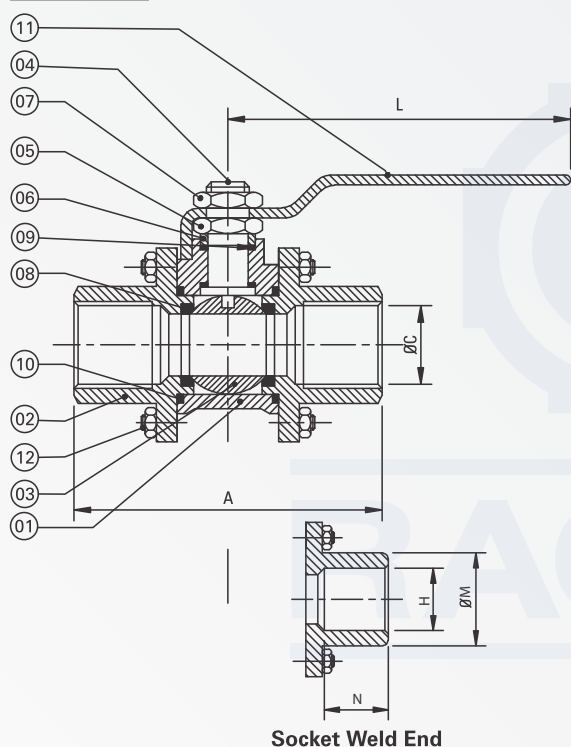

PRIMARY SERVICE RATING & TEST PRESSURE

Class	Hydro Test Pressure		Max. Temp.
	Body	Seat	
150	425 PSI	300 PSI	180°C
Air Test - Seat 80 PSI ± PSI			

Socket Weld End

BALL VALVE 3PC S/E

Size		A	ØC	L	Socket Weld End		
Inch	M.M.				H	ØM	N
1/2"	15	90	13	155	22.4	29	12.7
3/4"	20	90	19	160	27.3	35	19.0
1"	25	95	25	160	34.1	43	22.0
1.1/4"	32	110	32	160	43.0	54	22.0
1.1/2"	40	120	38	178	49.0	58	22.0
2"	50	130	50	178	61.3	71	23.0
2.1/2"	65	144	64	190	76.0	105	23.0
3"	80	160	79	190	90.0	108	23.0

S. N.	Parts Name	Material	Qty
01	Body	C.S. (ASTM A 216 Gr. WCB)	1
02	Body Connector	C.S. (ASTM A 216 Gr. WCB)	2
03	Ball	S.S. 202/304/316	1
04	Stem	S.S. 202/304/316	1
05	Gland Nut	M.S./S.S. 202/304/316	1
06	Gland Bush	M.S./S.S. 202/304/316	1
07	Lock Nut	M.S./S.S. 202/304/316	1
08	Seat Ring	PTFE/GFT	2
09	Stem Seal	PTFE/GFT	2
10	Body Sealant Ring	PTFE/GFT	2
11	Lever	M.S.	1
12	Stud & Nuts	M.S.	4

Note: (1) All Dimension are in mm
(2) Tolerance ± 3 mm
(3) Also available in CI on request

Application

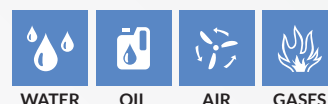

Forge Steel Ball Valves Screw End

Technical Data

Design & Manufacturing Std: BS 5351 / API 602
 Testing & inspection Std: API 598 / BS 5146
 End Connections: Screw : BSP / NPT / Socket Weld
 / Reduce Bore

Drawing »

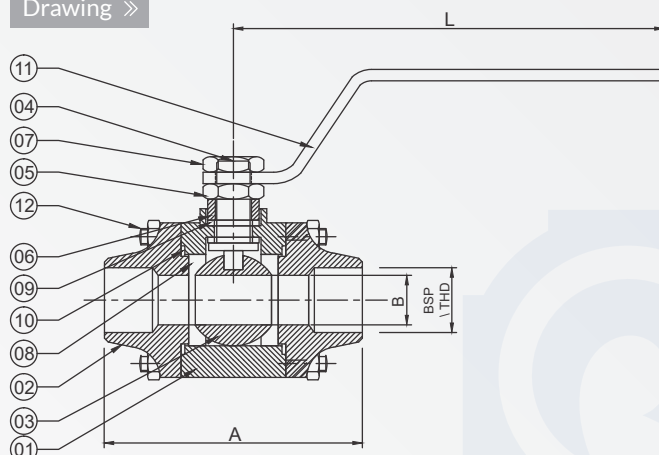

Sr. No.	Parts Name	Material	Qty
01	Body	ASTMA - 105, A-182 (F 304 & F 316)	1
02	Body Connector	ASTMA - 105, A-182 (F 304 & F 316)	2
03	Ball	AISI 304, 316	1
04	Stem	AISI 304, 316	1
05	Gland Nut	AISI 304, 316, M.S.	1
06	Gland Bush	S.S. 202/304/316	2
07	Lock Nut	AISI 304, 316, M.S.	1
08	Seat Ring	PTFE/GFT	2
09	Stem Seal	PTFE/GFT	2
10	Body Sealant Ring	PTFE/GFT	2
11	Lever	M.S. / S.S.	1
12	Stud & Nuts	193 B7 / S.S.	4

PRIMARY SERVICE RATING & TEST PRESSURE

Class	Hydro Test Pressure		Max. Temp.
	Body	Seat	
800	1100 PSI	800 PSI	180°C

F.S. BALL VALVES 3PC S/E

SIZE		DIMENSION		
Inch	M.M.	A	B	L
1/2"	15	85	12.5	125
3/4"	20	85	12.5	125
1"	25	105	18	155
1.1/2"	40	125	32	230
2"	50	130	38	230

Note: (1) All Dimension are in mm.
 (2) Tolerance ± 3 mm
 (3) Socket weld also available
 (4) Full bore valves also available

Application



I. C. Three Way Ball Valves Screw End



Technical Data

Design & Manufacturing Std: BS 5351 / API 602
 Testing & inspection Std: API 598 / BS 5146
 End Connections: BSP / NPT

Drawing »

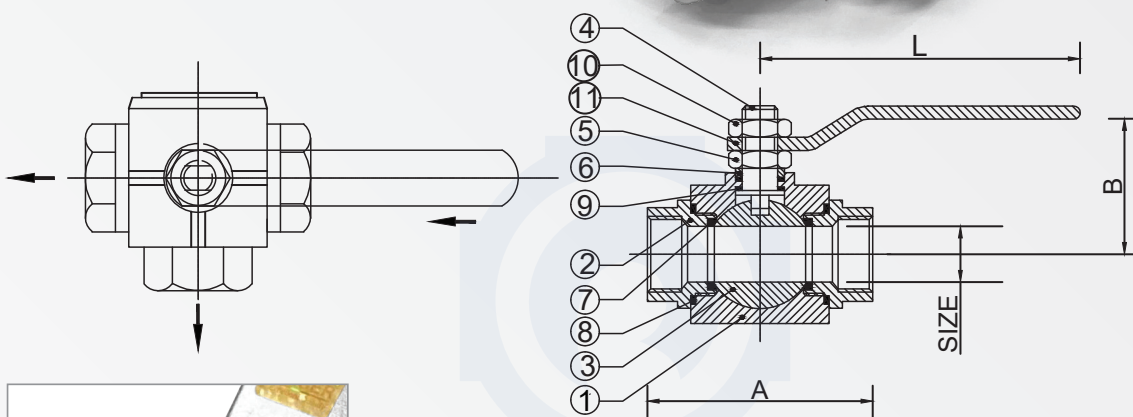

PRIMARY SERVICE RATING & TEST PRESSURE

Class	Hydro Test Pressure		Max. Temp.
	Body	Seat	
150	425 PSI	300 PSI	180°C
Air Test - Seat 80 PSI ± PSI			

I. C. THREE WAY BALL VALVE S/E

Size		A	B	L
Inch	M.M.			
1/2"	15	69	49	115
3/4"	20	80	53	135
1"	25	89	57	135
1.1/2"	40	140	86	170
2"	50	152	93	170

Sr. No.	Parts Name	Material	Qty
01	Body	ASTM A 351 Gr. CF8/CF8M/CF3/CF3M	1
02	Body Connector	ASTM A 351 Gr. CF8/CF8M/CF3/CF3M	3
03	Ball	AISI 304/316/304L/316L	1
04	Stem	AISI 304/316/304L/316L	1
05	Gland Nut	AISI 304/316/304L/316L	1
06	Gland Bush	AISI 202/304/316/304L/316L	1
07	Seat Ring	PTFE/GFT	4
08	Body Seal	PTFE/GFT	3
09	Steam Seal	PTFE/GFT	2
10	Lock Nut	AISI 304/316/304L/316L	2
11	Lever	M.S./S.S. 202/304/316	1

Note: (1) All Dimension are in mm
 (2) Tolerance ± 3 mm
 (3) Available in
 'T' Port & 'L' Port Ball Design

Application

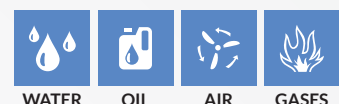

Three Way Ball Valves Flange End



Technical Data

Design & Manufacturing Std: BS 5351 / API 602
 Testing & inspection Std: API 598 / BS 5146
 End Connections: Flange End 150#

Drawing »

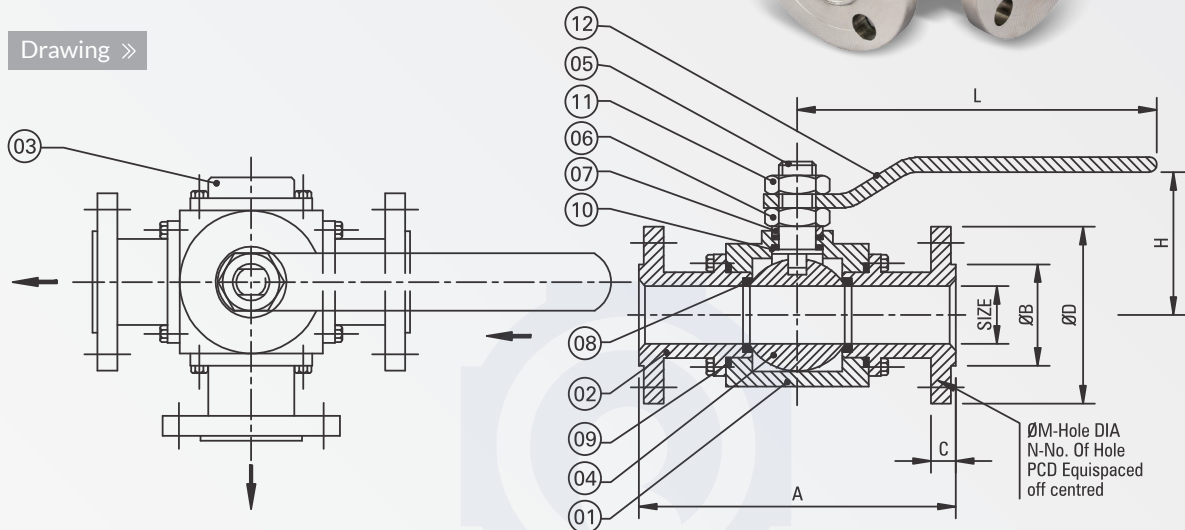

PRIMARY SERVICE RATING & TEST PRESSURE

Class	Hydro Test Pressure		Max. Temp.
	Body	Seat	
150	425 PSI	300 PSI	180°C
Air Test - Seat 80 PSI ± PSI			



S.N.	Parts Name	Material	Qty
01	Body	WCB (C.S.)/M.S./S.S. 202/304/316	1
02	Body Connector	WCB (C.S.)/M.S./S.S. 202/304/316	3
03	Body End Cap	WCB (C.S.)/M.S./S.S. 202/304/316	1
04	Ball	AISI 304/AISI 316/S.S. 202	1
05	Stem	AISI 304/AISI 316/S.S. 202	1
06	Gland Nut	AISI 304/AISI 316/S.S. 202	1
07	Gland Bush	AISI 304/AISI 316/S.S. 202	1
08	Seat Ring	PTFE/GFT	4
09	Body Seal	PTFE/GFT	4
10	Steam Seal	PTFE/GFT	2
11	Lock Nut	AISI 410/304/316	1
12	Lever	M.S./S.S. 202/S.S. 304	1

THREE WAY BALL VALVE F/E									
Size	A	ØB	C	ØD	L	H	ØM	N	PCD
15	108	35	10	89	150	56	16	4	60.4
20	118	43	10.5	98	150	62	16	4	69.8
25	150	51	11	108	200	77	16	4	79.2
32	160	64	12.7	117	200	81	16	4	88.9
40	185	73	14.2	127	250	90	16	4	98.5
50	245	92	15.7	152	250	103	19	4	120.6
65	275	105	17.5	178	300	130	19	4	139.7
80	300	127	19	190.5	300	137	19	4	152.4
100	370	157	24	229	500	177	19	4	190.5
125	395	186	24	254	500	201	22	8	215.0
150	480	216	25.5	279	500	221	22	8	241.3

Note: (1) All Dimension are in mm
 (2) Tolerance ± 3 mm
 (3) Available in
 'T' Port & 'L' Port Ball Design

Application

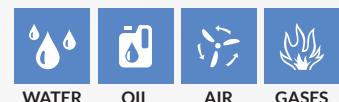

I. C. Flush Bottom Ball Valves

FLUSH BOTTOM

Technical Data

Design & Manufacturing Std: BS 5351 / API 6 D
 Testing & inspection Std: API 598 / BS 5146
 Face To Face: As per ANSI B 16.11
 End Connections: Flange as per ANSI B 16.5

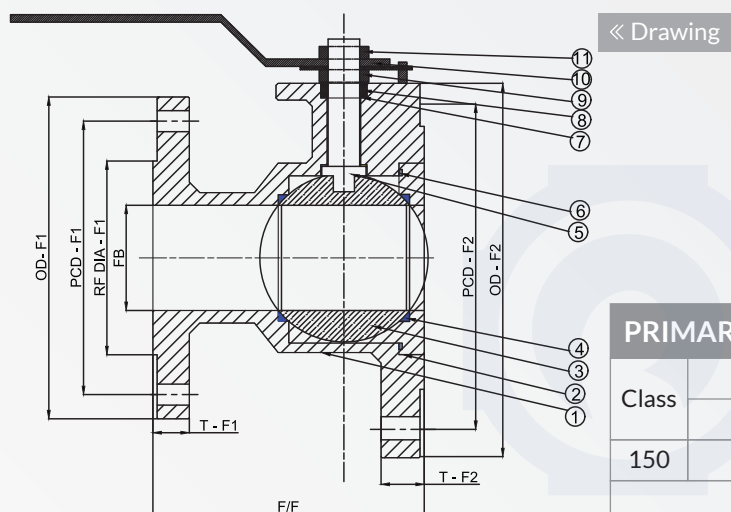
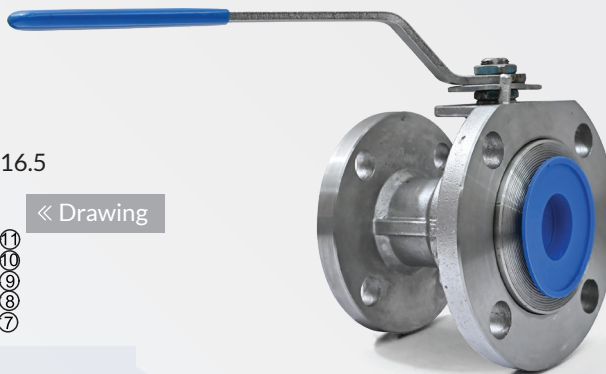

PRIMARY SERVICE RATING & TEST PRESSURE			
Class	Hydro Test Pressure		Max. Temp.
	Body	Seat	
150	425 PSI	300 PSI	180°C
Air Test - Seat 80 PSI ± PSI			

Sr. No.	Size (mm) F1x F2	FLANGE 1 DIMENSIONS								FLANGE 2 DIMENSIONS							
		FB	FF	O.D.	RF DIA	PCD	PCD Hole	No Hole	Flange Thickness	FB	FF	O.D.	RF DIA	PCD	PCD Hole	No Hole	Flange Thickness
1	25X40	25	79	108	50	79	16	4	11.5	25	79	126	73	98.5	16	4	13
2	40X50	38	109	126	72	98.5	16	4	15	38	109	150	91	121	19	4	17
3	50X80	50	123	152.5	90	121	19	4	17	50	123	190	125	152	19	4	19
4	80X100	75	157	190	127	152	19	4	19	75	157	229	157	191	19	8	20

S. N.	Parts Name	Material	Qty
01	Body	ASTM A 351 Gr. CF8/CF8M/CF3/CF3M	1
02	Body Nut	ASTM A 351 Gr. CF8/CF8M/CF3/CF3M	1
03	Ball	AISI 304/316/304 L/316 L	1
04	Seat Ring	PTFE/GFT	2
05	Stem	AISI 202/304/316/304 L/316 L	1
06	Body Sealant Ring	PTFE/GFT	1
07	Stem Seal	PTFE/GFT	2
08	Gland Bush	AISI 202/304/316/304 L/316 L	1
09	Gland Nut	AISI 202/304/316/304 L/316 L	1
10	Lever	M.S./S.S. 202/304/316	1
11	Lock Nut	AISI 202/304/316/304 L/316 L	1



Note: (1) All Dimension are in mm. (2) Tolerance ± 3 mm
 (3) 45° Lever Operation also available
 (4) 90° lever operation also available

Application



Jacketed Ball Valves Flange End

Technical Data

Low Operating Torque
 Leak Tight Stem Sealing
 Pressure Rating: 150#
 End Connection: Flange End RF
 Flange Drilling: As per ANSI B 16.5, 150#
 Face to Face: As per ANSI B16.10
 Operation: Manual Hand Lever Operated

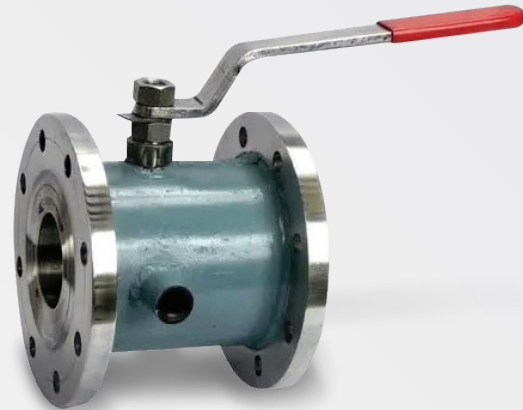

Drawing »

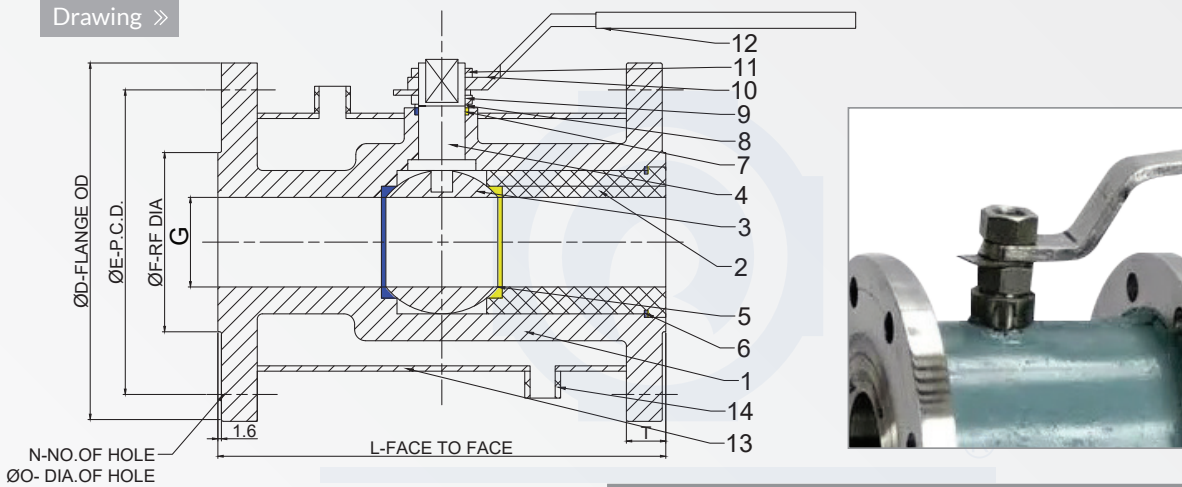

PRIMARY SERVICE RATING & TEST PRESSURE

Class	Hydro Test Pressure		Max. Temp.
	Body	Seat	
150	425 PSI	300 PSI	180°C
Air Test - Seat 80 PSI ± PSI			

S. N.	Parts Name	Material
01	Body	M.S./S.S. 304/S.S. 316
02	Nut	AISI 304/316
03	Ball	AISI 304/316
04	Stem	AISI 304/316
05	Ball Seat	PTFE/GFT/CFT
06	Body Seal	PTFE/GFT/CFT
07	Gland Seal	PTFE/GFT/CFT
08	Gland Bush	All 304/316
09	Gland Nut	CS/194 Gr. 2H/SS304/SS316
10	Hand Lever	CS/SS
11	Hand Lever Nut	CS/194 Gr. 2H/SS304/SS316
12	Jacket (Fabricated)	M.S./SS304/SS316
13	Coupling	M.S./SS304/SS316

STANDARD DIMENSION (150#)								
Size	25x40	40x50	50x65	50x80	65x80	80x100	100x150	
L	127	165	178	178	190	203	229	
G	25	38	50	50	63	75	100	
ØD	127	152.4	177.8	190.5	190.5	228.6	279	
ØE	98.5	120.6	139.7	152.4	152.4	190.5	241.3	
ØF	73	92.1	104.7	127	127	157.2	215.9	
N	4	4	4	4	4	8	8	
ØO	15.8	19	19	19	19	19	22	
T	14.3	15.8	17.7	19	19	23	25.4	

Note: (1) All Dimension are in mm
 (2) Tolerance ± 3 mm

I. C. Ball Valves Tri Clover End (TC)

Technical Data

Design & Manufacturing Std: BS 5351
Testing & inspection Std: API 598 / BS 5146



Drawing »

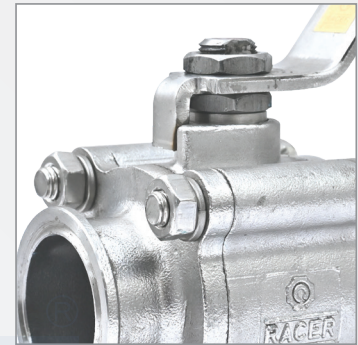
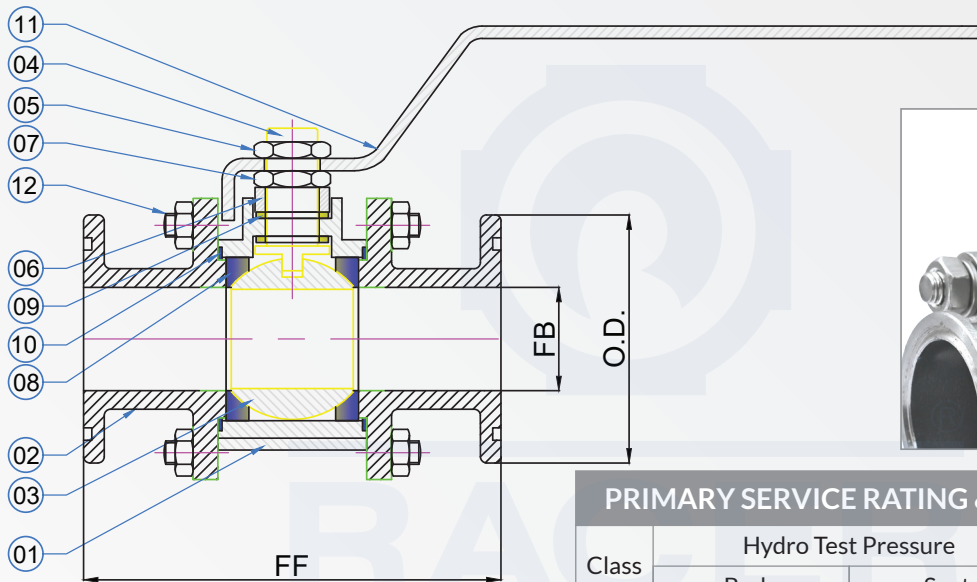

TCN BALL VALVE			
Size	OD	FB	FF
15MM	35	12.5	82
20MM	35	18	87
25MM	51	24	90
40MM	51	38	100
50MM	65	50	125

PRIMARY SERVICE RATING & TEST PRESSURE			
Class	Hydro Test Pressure		Max. Temp.
	Body	Seat	
150	425 PSI	300 PSI	180°C
Air Test - Seat 80 PSI ± PSI			

S. N.	Parts Name	Material	Qty
01	Body	ASTM A351 GR CF8/CF8M/CF3/CF3M	1
02	TC Connector	ASTM A351 GR CF8/CF8M/CF3/CF3M	2
03	Ball	AISI 304/316/304L/316L	1
04	Stem	AISI 304/316/304L/316L	1
05	Lock Nut	AISI 304/316/304L/316L	1
06	Gland	AISI 202/304/316/304L/316L	1
07	Gland Nut	AISI 304/316/304L/316L	1
08	Seat Ring	PTFE/GFT	2
09	Stem Seal	PTFE/GFT	2
10	Body Sealant Ring	PTFE/GFT	2
11	Lever	S.S. -202/304/316	1
12	Stud & Nuts	S.S. -202/304/316	-

Note: (1) All Dimension are in mm
(2) Tolerance ± 3 mm

Application



Butterfly Valves (PN 10)

Technical Data

Design & Manufacturing Std: API 609 / IS: 13095
 Testing & inspection Std: API 598 / IS 13095
 Temp. Rating: Material will be selected according to service

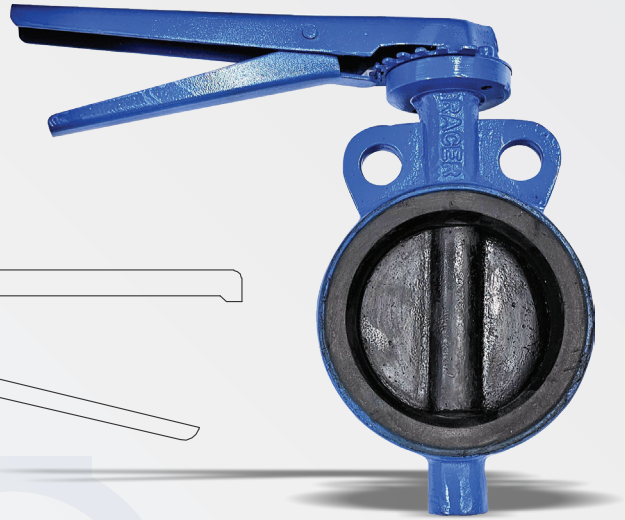

Drawing »

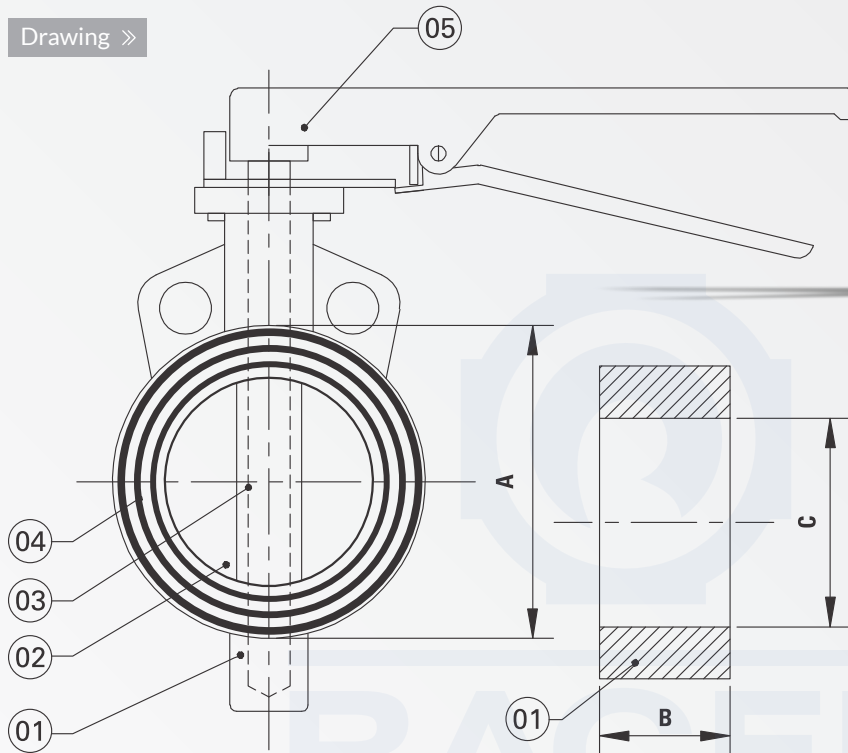

SIZE		A	B	C
Inch	M.M.			
1 1/2"	40	71	39	40
2"	50	78	43	50
2 1/2"	65	103	48	64
3"	80	119	49	80
4"	100	138	55	100
5"	125	163	55	125
6"	150	194	56	147
8"	200	256	62.5	196
10"	250	315	71	241
12"	300	373	80	294

Sr. No.	Parts Name	Material	Qty
01	Body	C. I./C. S./S.S. 202/S.S. 304/S.S. 316	1
02	Disc	C. I./D. I./S.G. Iron/C. S./CF8/CF8M	1
03	Spindle	AISI 410/S.S. 304/S.S. 316	1
04	Rubber Lining	Nitrile/EPDM/Viton/Silicon	1
05	Lever	M.S./S.S./Gear Operated	1

Primary Service Rating & Test Pressure			
Hydro Test Pressure			
Class	Body	Seat	Mini - Max Temp.
PN 10	15 Bar	10 Bar	60°C - 200°C

Note: (1) All Dimension are in mm.
 (2) Tolerance ± 3 mm
 (3) Butterfly range available upto 28"
 (4) Gear Operated also available

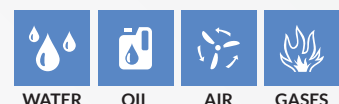

Butterfly Valves (PN 16)

Technical Data

Design & Manufacturing Std: API 609 / IS: 13095
 Testing & inspection Std: API 598 / IS 13095
 Temp. Rating: Material will be selected according to service

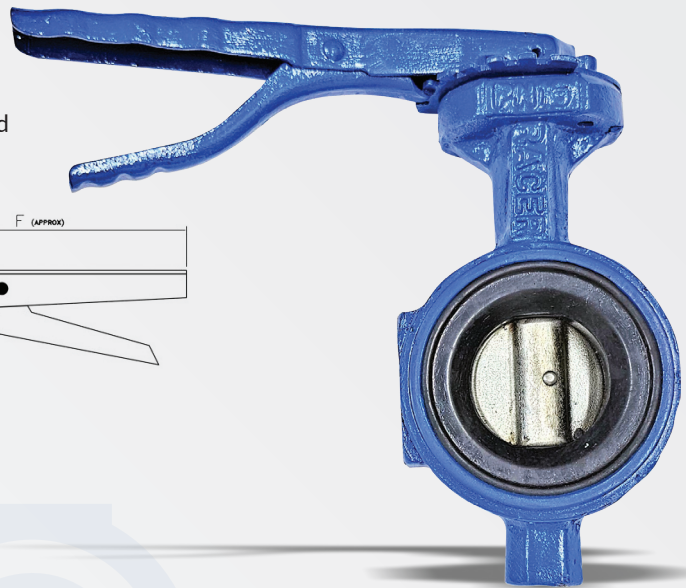

Drawing »

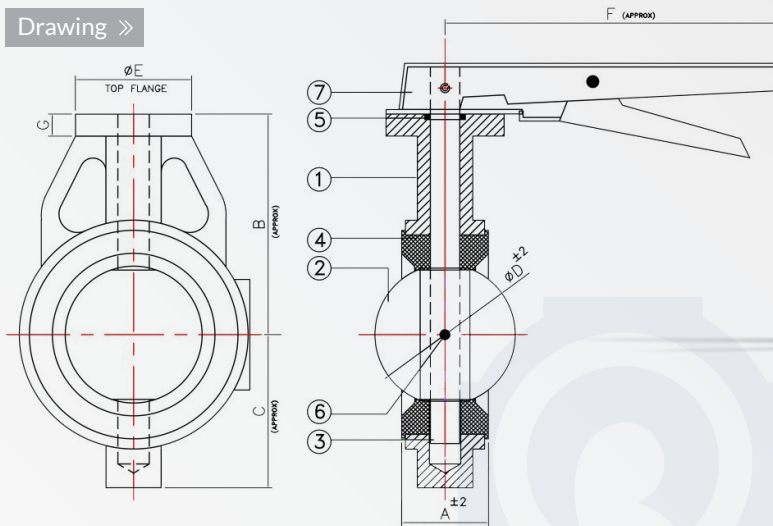

SIZE		A	B	C	D	E	F	G	Top Flange Mounting ISO 5211
Inch	M.M.								
1 1/2"	40	36	92	52	40	65	180	15	F05
2"	50	43	103	70	50	65	180	15	F05
2 1/2"	65	46	110	76	63	65	180	15	F05
3"	80	46	118	85	76	65	215	15	F05
4"	100	52	148	102	100	65	215	15	F05
5"	125	56	164	115	125	65	215	15	F05
6"	150	56	176	130	150	65	265	15	F05
8"	200	60	230	156	200	75	325	15	F07
10"	250	68	266	196	250	-	-	18	F10
12"	300	78	300	230	298	-	-	18	F10
14"	350	92	320	272	348	-	-	22	F12
16"	400	102	385	302	394	-	-	22	F14

Primary Service Rating & Test Pressure			
	Hydro Test Pressure		
Class	Body	Seat	Mini - Max Temp.
PN 16	22 Bar	16 Bar	60°C - 200°C

S.N.	Parts Name	Material
01	Body	Cast Iron/Cast Steel/S.S. 304-316
02	Disc	Cast Iron/Cast Steel/S.S. 304-316
03	Spindle	S.S. 410/304/316
04	Body Lining	Nitrile/EPDM/Silicon/Viton/Hypalon
05	'O' Ring	Nitrile/EPDM
06	Pin	S.S. 304/316
07	Lever	M.S. Fabricated

Note: (1) All Dimension are in mm.
 (2) Tolerance ± 3 mm
 (3) Butterfly range available upto 28"
 (4) Gear Operated also available

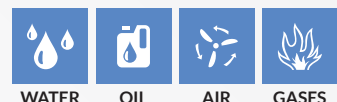

PTFE Lined Ball Valves Lever Operated

Drawing »

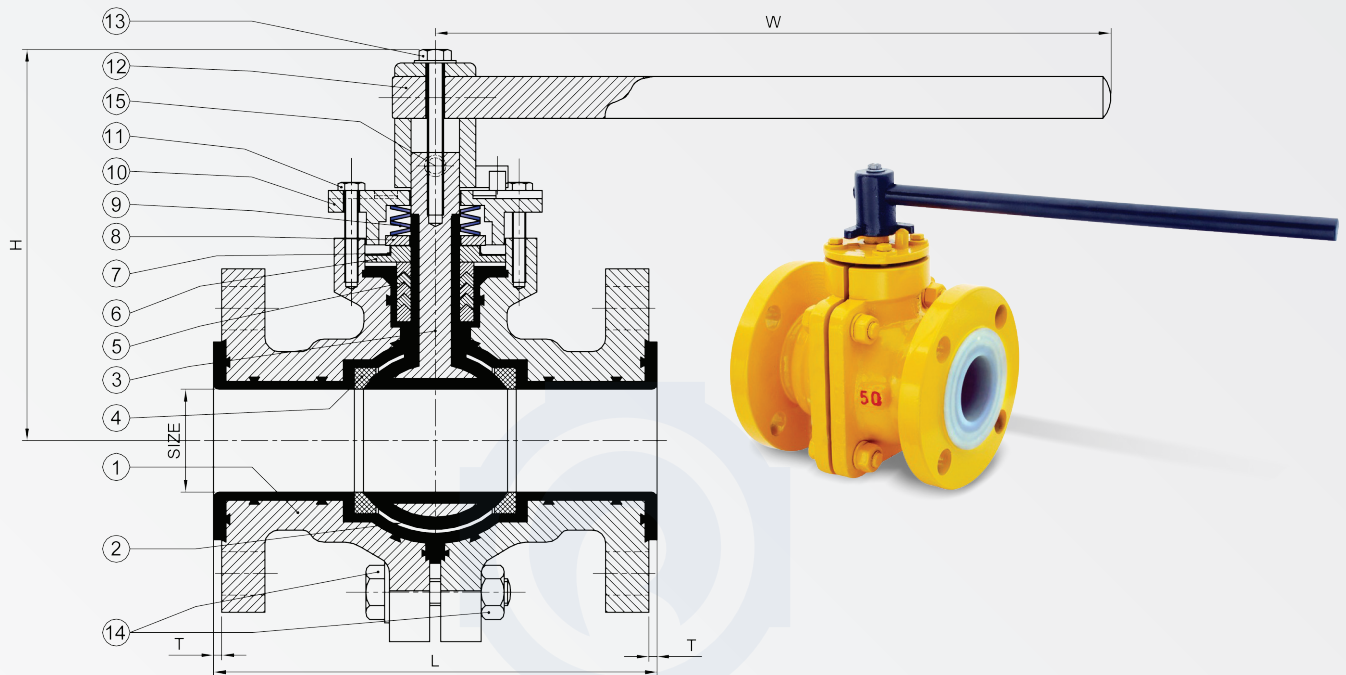

M/c. Devition for linear as per ISO 2768-m								
Dimn	Over	0.5	6	30	120	400	1000	2000
	Upto	6	30	120	400	1000	2000	4000
Tolerance		±0.1	±0.2	±0.3	±0.5	±0.8	±1.2	±2

PTFE BALL VALVES				
Size	L	H	W	T
1"	127	116	165	3.5
1.1/2"	165	135	255	3.5
2"	178	156	315	3.5
3"	203	172	415	3.5
4"	229	199	450	3.5

S. N.	Parts Name	Material
01	Body	SG Iron, WCB or S.S.
02	Ball	PFA/FEP Lined MS or S.S.
03	Stem	Lined M.S. or S.S.
04	Seat Ring	PTFE
05	Chavron Packing	PTFE
06	Diaphram	PTFE
07	S.S. Diapharam	S.S.
08	Thrust Washer	M.S., S.S.
09	Disc Spring	Spring Steel
10	Gland Housing	M.S./S.S.
11	Bolt & Washer	M.S./S.S.
12	Handle	M.S./S.S.
13	Lock Bolt	M.S./S.S.
14	Bolt, Nuts & Washer	M.S./S.S.
15	Gub Screw	M.S./S.S.

Note: (1) All Dimension are in mm
(2) Tolerance ± 3 mm



PTFE Lined Butterfly Valves Lever Operated

Technical Data

Design & Manufacturing Std: API 609
 Drilling Standard: Universal
 Max, Service Temp: FEP: 160° C
 PFA: 160° C

Drawing »

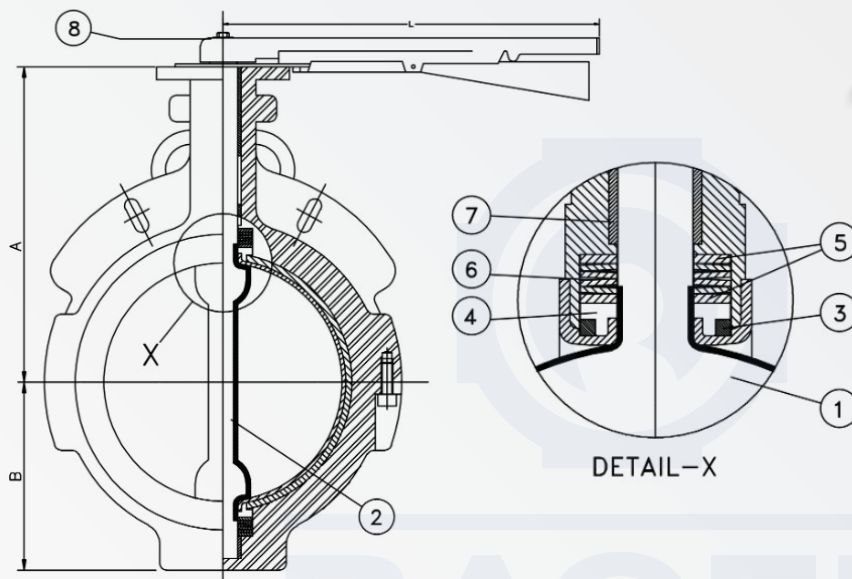

PTFE LINED BUTTERFLY VALVES					
Size	F/F	A	B	L	Kg. Wt.
50	43	100	70	265	4.2
65	46	114	75	265	5.1
80	46	120	80	265	5.7
100	52	158	110	350	7.8
125	56	175	125	350	10
150	56	190	130	430	13.2
200	60	220	160	430	29.3
250	68	250	185	G.Box	51.5
300	78	285	215	G.Box	70.6
350	78	325	285	G.Box	90.6

S. N.	Parts Name	Material
01	Lever Assly.	C.S.
02	Guide Bush	S.S. AISI 304
03	Cup Washers	Spring Steel Nickel Plated
04	Thrust Washers	S.S. AISI 304
05	Thrust Collar	PTFE
06	Elastomer Backing	Silicon
07	Disc with Integral Shaft	AISI 304/316/FEP/PFA Lined
08	Body Liner 3mm Thick	PTFE/FEP/PFA

Note: (1) All Dimension are in mm
 (2) Tolerance ± 3 mm
 (3) Butterfly range available upto 28"

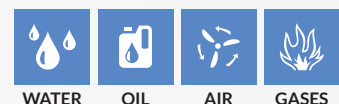

Gate Valves Flange End

GATE VALVE 150#

Technical Data

Design & Manufacturing Std:	ANSI B 16.34 / API 600
Testing & inspection Std:	API 598
Face To Face:	As per ANSI B 16.10
End Connections:	Flange as per ANSI B 16.5

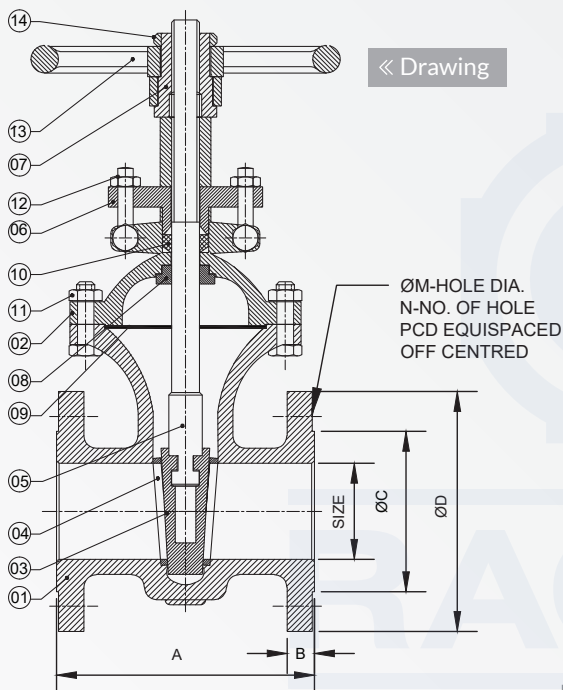
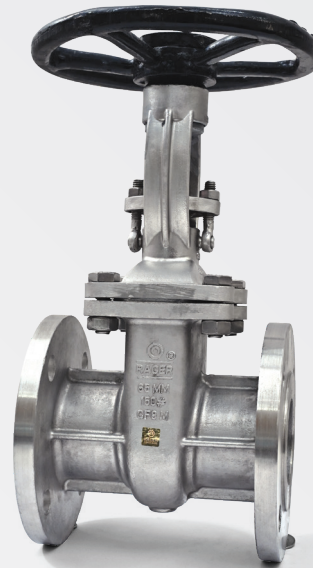

PRIMARY SERVICE RATING & TEST PRESSURE

Class	Hydro Test Pressure		Max. Temp.
	Body	Seat	
150	425 PSI	300 PSI	300°C
Air Test - Seat 80 PSI ± PSI			

GATE VALVE F/E 150#							
Size	A	B	ØC	ØD	ØM	N	PCD
25	127	11.1	51	108	16	4	79.2
40	165	14.2	73	127	16	4	98.5
50	178	15.7	92	152	19	4	120.5
65	190	17.5	105	178	19	4	140
80	203	19	127	190	19	4	152
100	229	24	157	229	19	8	190.5
125	254	24	186	254	22	8	216
150	267	25.4	216	279	22	8	241
200	292	28.4	270	343	22	8	298
250	330	30	324	406	25	12	362
300	356	31.5	381	483	25	12	432

S. N.	Parts Name	Material	Qty
01	Body	CF8/CF8M/C. I./C. S.	1
02	Bonnet	CF8/CF8M/C. I./C. S.	1
03	Wedge	CF8/CF8M/AISI 410 (13%CR)	1
04	Seat Ring	CF8/CF8M/AISI 410 (13%CR)	1
05	Stem	CF8/CF8M/AISI 410 (13%CR)	1
06	Gland	S.S./C. S.	1
07	Yoke Sleeve	Cast Steel/Cast Iron	1
08	Bonnet Bush	SS/AISI 410	1
09	Gasket	Spiral Wound Metallic	1
10	Gland Packing	Graphoil	-
11	Bonnet Stud & Nut	S.S./M.S.	-
12	Eye Bolt & Nut	S.S./M.S.	2
13	Hand Wheel	Cast Iron/S.G. Iron	1

Note: (1) All Dimension are in mm
(2) Tolerance ± 3 mm

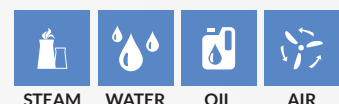

Globe Valves Flange End

GLOBE VALVE 150#

Technical Data

Design & Manufacturing Std:	BS 5351 / API 6 D
Testing & inspection Std:	API 598 / BS 5146
Face To Face:	As per ANSI B 16.11
End Connections:	Flange as per ANSI B 16.5

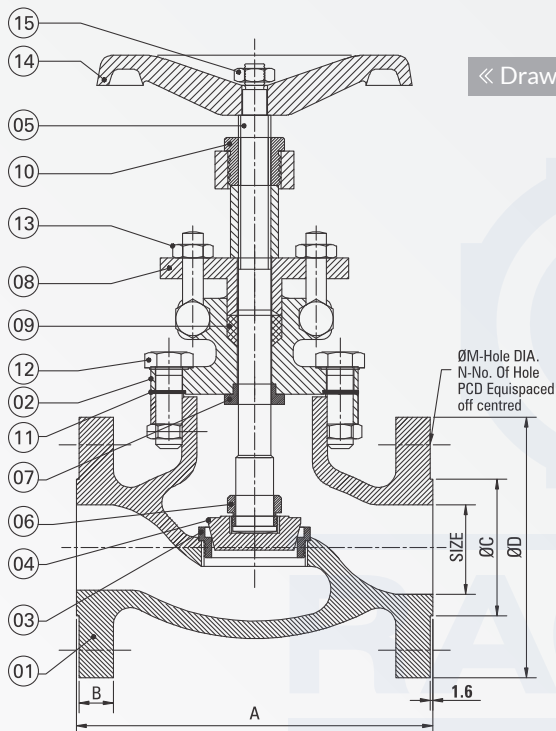

« Drawing



PRIMARY SERVICE RATING & TEST PRESSURE

Class	Hydro Test Pressure		Max. Temp.
	Body	Seat	
150	425 PSI	300 PSI	300°C
Air Test - Seat 80 PSI ± PSI			

GLOBE VALVE F/E 150#							
Size	A	B	ØC	ØD	ØM	N	PCD
25	127	11.1	51	108	16	4	79.2
40	165	14.2	73	127	16	4	98.5
50	203	15.7	92	152	19	4	120.5
65	216	17.5	105	178	19	4	140
80	241	19	127	190	19	4	152
100	292	24	157	229	19	8	190.5
125	356	24	186	254	22	8	216
150	406	25.4	216	279	22	8	241
200	495	28.4	270	343	22	8	298
250	622	30.2	324	406	25	12	362
300	698	31.7	381	483	25	12	432

S. N.	Parts Name	Material	Qty
01	Body	CF8/CF8M/C. I./C. S.	1
02	Bonnet	CF8/CF8M/C. I./C. S.	1
03	Seat Ring	CF8/CF8M/C. I./C. S.	1
04	Globe	CF8/CF8M/AISI 410 (13%CR)	1
05	Stem	CF8/CF8M/AISI 410 (13%CR)	1
06	Stem Nut	S.S./AISI 410 (13% CR)	1
07	Bonnet Bush	S.S./AISI 410	1
08	Gland	S.S./Carbon Steel	1
09	Gland Packing	Metallic Wire Reniforced Graph Oil	-
10	Yoke Sleeve	Cast Steel/ Ni-resist	1
11	Bonnet Gasket	Spiral Wound Metallic/CAF	1
12	Bonnet Stud & Nut	S.S./M.S.	-
13	Eye Bolt & Nut	S.S./M.S.	2
14	Hand Wheel	Cast Iron/S.G. Iron	1
15	Hand Wheel Nut	Cast Steel	1

Note: (1) All Dimension are in mm
(2) Tolerance ± 3 mm

I. C. Gate Valves Screw End

Technical Data

Design & Manufacturing Std:	ANSI B 16.34 / API 600
Testing & inspection Std:	API 598
Face To Face:	As per ANSI B 16.10
End Connections:	Screw - BSP/NPT



Drawing »

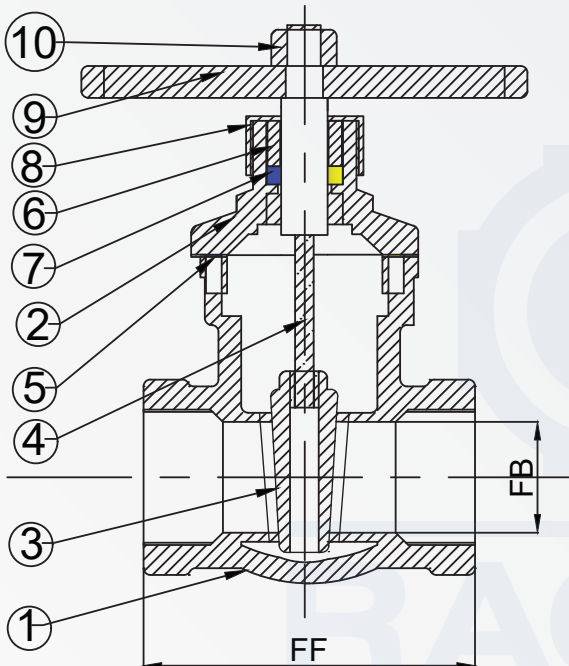

PRIMARY SERVICE RATING & TEST PRESSURE

Class	Hydro Test Pressure		Max. Temp.
	Body	Seat	
150	425 PSI	300 PSI	300°C
Air Test - Seat 80 PSI ± PSI			

I. C. S/E GATE VALVE

Size		FF	FB
Inch	M.M.		
1/2"	15	54	13
3/4"	20	61	19
1"	25	72	25
1.1/2"	40	80	38
2"	50	93	50

S. N.	Parts Name	Material	Qty
01	Body	ASTM A351 GR. CF8/CF8M/CF3/CF3M	1
02	Bonnet	ASTM A351 GR. CF8/CF8M/CF3/CF3M	1
03	Wedge	ASTM A351 GR. CF8/CF8M/CF3/CF3M	1
04	Stem	AISI 304/316/304L/316L	1
05	Body Sealent Ring	PTFE	1
06	Gland	SS 202/304/316	1
07	Gland Packing	PTFE/Grafoil	-
08	Bonnet Nut	AISI 304/316/304L/316L	1
09	Hand Wheel	Cast Iron/M.S.	1
10	Hand Wheel Nut	SS 202/304/316	1

Note: (1) All Dimension are in mm
(2) Tolerance ± 3 mm



I. C. Globe Valves Screw End

Technical Data

Design & Manufacturing Std:	ANSI B 16.34 / API 600
Testing & inspection Std:	API 598
Face To Face:	As per ANSI B 16.10
End Connections:	Screw - BSP/NPT

Drawing »

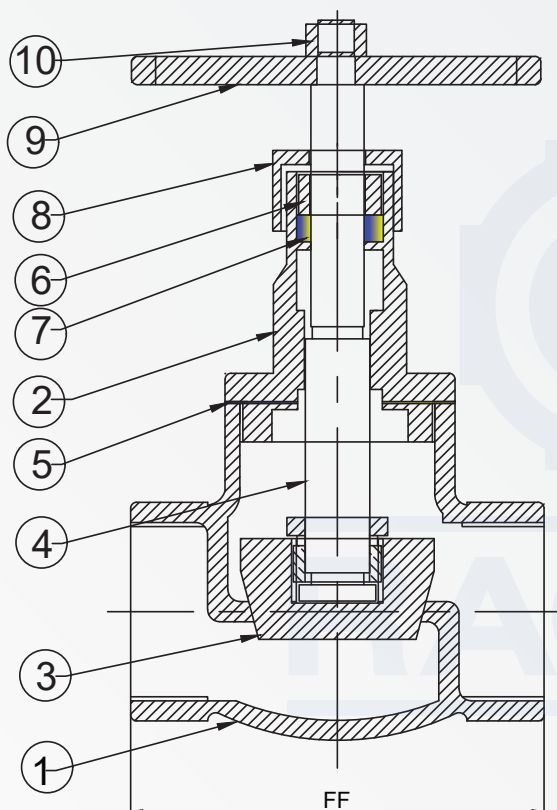

PRIMARY SERVICE RATING & TEST PRESSURE

Class	Hydro Test Pressure		Max. Temp.
	Body	Seat	
150	425 PSI	300 PSI	300°C
Air Test - Seat 80 PSI ± PSI			

I C S/E GLOBE VALVE		
Size		FF
Inch	M.M.	
1/2"	15	61
3/4"	20	69
1"	25	81
1.1/2"	40	101
2"	50	122

S. N.	Parts Name	Material	Qty
01	Body	ASTM A351 GR. CF8/CF8M/CF3/CF3M	1
02	Bonnet	ASTM A351 GR. CF8/CF8M/CF3/CF3M	1
03	Globe	AISI 304/316/304L/316L	1
04	Stem	AISI 304/316/304L/316L	1
05	Body Sealent Ring	PTFE	1
06	Gland	SS 202/304/316	1
07	Gland Packing	PTFE/Grafoil	-
08	Bonnet Nut	AISI 304/316/304L/316L	1
09	Hand Wheel	Cast Iron/M.S.	1
10	Hand Wheel Nut	SS 202/304/316	1

Note: (1) All Dimension are in mm
(2) Tolerance ± 3 mm

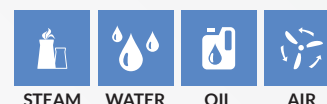

Forged Steel Gate Valves & Globe Valves

Technical Data (Gate Valves)

Design & Manufacturing Std: BS 5352
 Testing & inspection Std: BS 6755 (Part-1)
 Face To Face: As per ANSI B 16.10
 End Connections: Screw End to BSP/NPT

Technical Data (Globe Valves)

Design & Manufacturing Std: BS 5352 / API 602
 Testing & inspection Std: BS 6755 (Part-1) / API 598
 Face To Face: As per ANSI B 16.10
 End Connections: Screw End to BSP/NPT

« Drawing

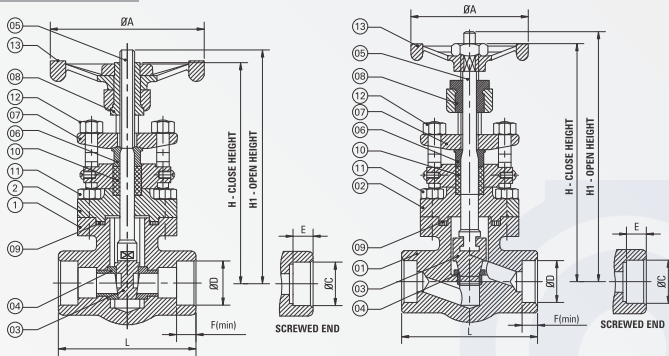

S. N.	Parts Name	Material	Qty
01	Body	ASTM A 105/F11/F12/F22/F304/F316	1
02	Bonnet	ASTM A 105/F11/F12/F22/F304/F316	1
03	Disc	AISI 410/304/316	1
04	Seat Ring	AISI 410/304/316	1
05	Spindle	AISI 410/304/316	1
06	Gland	AISI 410/304/316	1
07	Gland Flange	ASTM A 105/Carbon Steel/F304	1
08	Stem Nut	NI-Rest-A 439 Gr. D2/EN 1A	1
09	Bonnet Gasket	Asbestos Filler SS 304 Spiral Wounded	1
10	Gland Packing	Graphite Asbestos with S.S. wire	Req
11	Bonnet Bolts	ASTM A 193 Gr. B7/B8	4
12	Eye Bolt & Nut	Carbon Steel / S.S. 304	2
13	Hand Wheel	C.I./M.S./D.I	1

TEST PRESSURE			
Testing	Hydraulic		Pneumatic
	800#	1500#	
Body	3000 PSIG	5400 PSIG	-
Back Seat	2000 PSIG	4000 PSIG	-
Seat	2000 PSIG	4000 PSIG	80 PSIG

FORGED STEEL GATE VALVES CLASS 800#									
Size	L	H	H1	ØA	Scr. Ends		ØD SW Ends		
					ØC	E	Max	Min	F-Min
15	85	162	170	90	1/2"	13.56	22.22	21.72	9.65
20	92	170	180	90	3/4"	13.87	27.56	27.05	12.70
25	105	190	202	90	1"	17.35	34.29	33.78	12.70
40	127	213	260	145	1 1/2"	18.38	49.15	48.84	12.70
50	140	255	272	145	2"	19.23	61.62	61.11	15.75

FORGED STEEL GLOBE VALVES CLASS 800#									
Size	L	H	H1	ØA	Scr. Ends		ØD SW Ends		
					ØC	E	Max	Min	F-Min
15	85	152	165	90	1/2"	13.56	22.22	21.72	9.65
20	92	161	176	90	3/4"	13.87	27.56	27.05	12.70
25	105	175	198	90	1"	17.35	34.29	33.78	12.70
40	127	240	278	145	1 1/2"	18.38	49.15	48.84	12.70
50	140	255	298	145	2"	19.23	61.62	61.11	15.75

FORGED STEEL GATE VALVES CLASS 1500#									
Size	L	H	H1	ØA	Scr. Ends		ØD SW Ends		
					ØC	E	Max	Min	F-Min
15	92	170	180	90	1/2"	13.56	22.22	21.72	9.65
20	105	190	202	90	3/4"	13.87	27.56	27.05	12.70
25	127	243	260	145	1"	17.35	34.29	33.78	12.70
40	140	255	272	145	1 1/2"	18.38	49.15	48.64	12.70

FORGED STEEL GLOBE VALVES CLASS 1500#									
Size	L	H	H1	ØA	Scr. Ends		ØD SW Ends		
					ØC	E	Max	Min	F-Min
15	92	161	176	90	1/2"	13.56	22.22	21.72	9.65
20	105	175	198	90	3/4"	13.87	27.56	27.05	12.70
25	127	240	278	145	1"	17.35	34.29	33.78	12.70
40	140	255	298	145	1 1/2"	18.38	49.15	48.64	12.70

Note: (1) All Dimension are in mm
 (2) Tolerance ± 3 mm

Application





RACER
RACER VALVES PRIVATE LIMITED

I. C. Disc Check Valves (DCV) Non Return Valves

Technical Data

Design & Manufacturing Std: As per Mfr's Std.

Testing & inspection Std: API 598

Pressure Class: PN 16 / PN 40

Drawing »

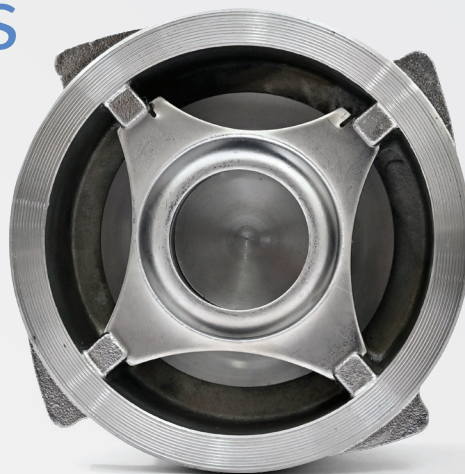
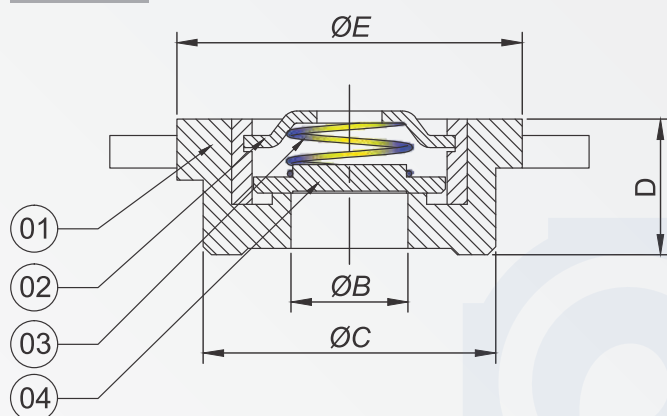

DCV					
Size	A	ØB	ØC	D	ØE
15	59	15	37	17	42
20	68	20	44	19	52
25	79	25	55	22	60
32	87	32	64	28	72
40	99	40	77	31	84
50	113	50	91.5	40	94
65	137	62	107	46	114
80	151	79	122	50	132
100	179	100	142	61	155
125	216	125	170	90	186
150	256	150	205	107	215
200	317	200	260	140	277

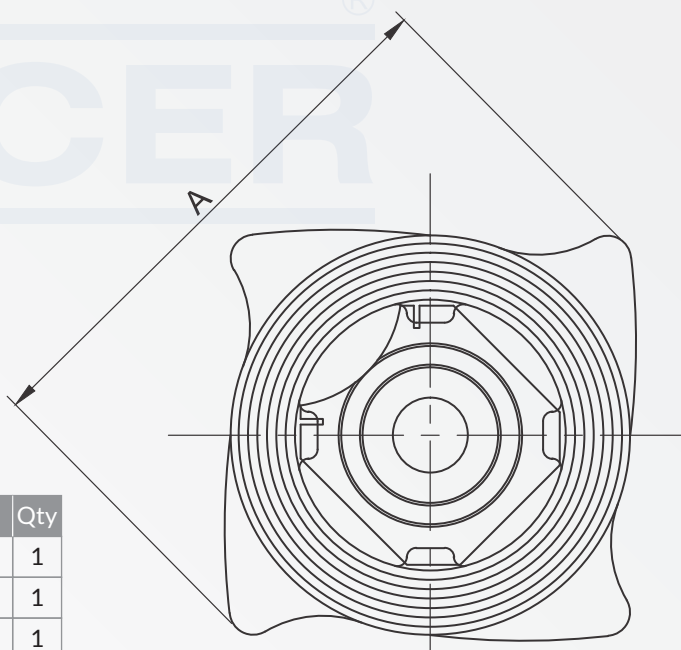

S. N.	Parts Name	Material	Qty
01	Body	ASTM A 351 Gr. CF8/CF8M	1
02	Spring	S.S. 202/304/316	1
03	Lock Plate	S.S. 202/304/316	1
04	Cover Plate	ASTM A 351 Gr. CF8/CF8M	1

Note: (1) All Dimension are in mm
(2) Tolerance ± 1.5 mm

Application



I. C. Wafer Check Valves (NRV)

Technical Data

Design & Manufacturing Std: API 6 D / ANSI B 16.34
 Testing & inspection Std: API 598
 Pressure Class: PN 10

Drawing »

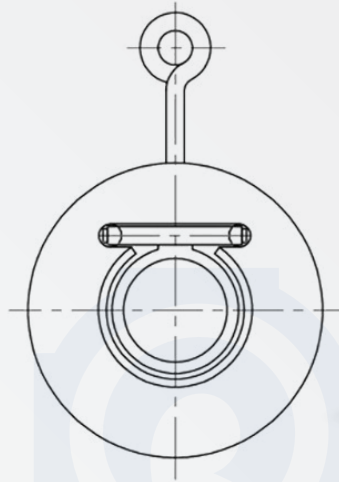
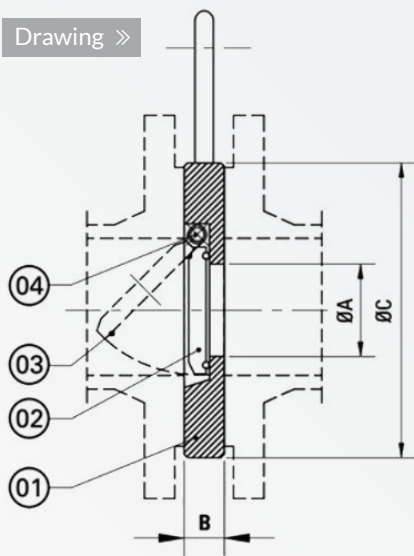

I. C. WAFER CHECK VALVE

Size		Dimension		
Inch	M.M.	ØA	B	ØC
1 1/2"	40	19.5	17	79
2"	50	27.5	17	94
2 1/2"	65	37.5	17	109
3"	80	48.5	17	125
4"	100	69	17	154
5"	125	91	17	184
6"	150	111	17	212
8"	200	153	24	260
10"	250	189	24	302
12"	300	225	24	352

S. N.	Parts Name	Material	Qty
01	Body	IC CF8 / CF8M	1
02	Disc	IC CF8 / CF8M	1
03	O Ring	PTFE Seat Only	1
04	Hinge	M.S.	1

PRIMARY SERVICE RATING & TEST PRESSURE

Class	Hydro Test Pressure		Max. Temp.
	Body	Seat	
PN 10	225 PSI	150 PSI	180°C

Note: (1) All Dimension are in mm
 (2) Tolerance ± 3 mm
 (3) Confirm exact application at time of order

Wafer Check Valves (NRV) (Barstock)

Technical Data

Design & Manufacturing Std: API 6D / ANSI B 16.34
 Testing & inspection Std: API 598
 Pressure Class: PN 10 / PN 16



Drawing »

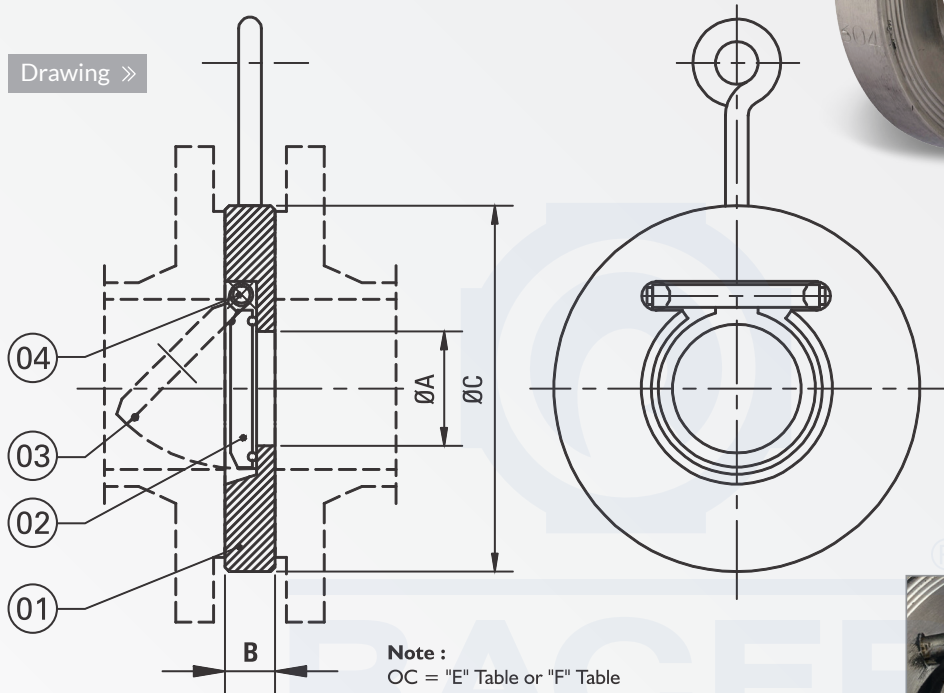

WAFER CHECK VALVE					
Size		Dimension		ØC	
Inch	M.M.	ØA	B	"E"	"F"
1 1/2"	40	12.5	18	74	92
2"	50	25	18	94	109
2 1/2"	65	32	18	110	129
3"	80	45	18	125	144
4"	100	68	18	155	164
5"	125	85	18	184	194
6"	150	110	18	210	219
8"	200	157	25	260	274
10"	250	195	25	305	330
12"	300	200	25	357	380

PRIMARY SERVICE RATING & TEST PRESSURE		
Class	Hydro Test Pressure	
	Body	Seat
PN 10	225 PSI	150 PSI

S. N.	Parts Name	Material	Qty
01	Body	C.I./M.S./S.S. 202/304/316	1
02	Disc	C.I./M.S./S.S. 202/304/316	1
03	'O' Ring	Nitrile, EPDM	1
04	Hinge	M.S.	1

Note: (1) All Dimension are in mm
 (2) Tolerance ± 3 mm

Application

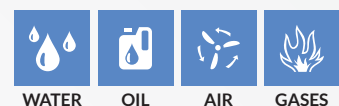

Swing Check Valves (NRV)

Technical Data

Design & Manufacturing Std: BS 1873
 Testing & inspection Std: API 598 / BS 5145
 Face To Face: As Per ANSI B 16.10
 End Connections: Flanged As Per ANSI 16.5 RF

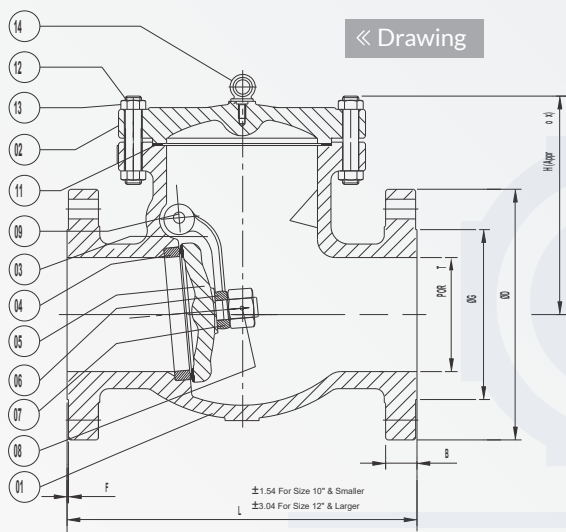

SWING CHECK VALVE									
Size	FB	L	H	ØD	B	ØG	ØJ	PSD	N
25	25	127	95	108	11.18	50.8	15.75	79.25	04
32	32	139.8	102	117	12.7	63.5	15.75	89	04
40	38	165.2	110	127	14.22	73.15	15.75	98.5	04
50	51	203	130	154.4	15.75	92	19.05	120.65	04
65	64	216	140	178	17.53	104.65	19.05	139.7	04
80	76	241.3	162	190.5	19.05	127	19.05	152.4	04
100	102	292	187	228.6	23.88	157.23	19.05	190.5	08
125	127	330	217	254	23.88	185.67	22.35	216	08
150	152	355.6	235	279.4	25.4	215.9	22.35	241.3	08
200	203	465.3	285	343	28.45	270	22.35	298.45	08
250	254	622.3	338	406	30.23	324	25.40	362	12
300	305	698.5	380	483	31.75	381	25.40	432	12



S. N.	Parts Name	Material	Qty
01	Body	ASTM A 216 Gr. WCB	1
02	Cover	ASTM A 216 Gr. WCB	1
03	Hinge	ASTM A 216 Gr. WCB	1
04	Sear Ring	AISI 410/ASTM A 217 Gr. Ca15	1
05	Disc	ASTM A 217 Gr. Ca15/WCB+13 Cr. Facing	1
06	Disc Returning Nut	AISI 304	1
07	Disc Washer	AISI 304/410	1
08	Cotter Pin	AISI 304	1
09	Hinge Pin	AISI 410	1
10	Plug	Carbon Steel	1
11	Cover Gasket	Asbestos Filler SS 304 Spiral Wounded/Caf	1
12	Cover Studs	M.S.	Req.
13	Cover Nuts	M.S.	Req.
14	Lifting Eye Ball	Carbon Steel	1

PRIMARY SERVICE RATING & TEST PRESSURE

Class	Hydro Test Pressure		Max. Temp.
	Body	Seat	
150	425 PSI	300 PSI	200°C
Air Test - Seat 80 PSI ± PSI			

Note: (1) All Dimension are in mm
 (2) Tolerance ± 3 mm

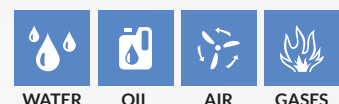

Dual Plate Check Valves

NRV



Technical Data

Design & Manufacturing Std: API 594 / API 6D
 Valve Face To Face Dimension: API 594
 Flange Standard Conformity: As Per ANSI B 16.10
 End Connections: Wafer type to suit between two flange as per ANSI B 16.5 150#
 Inspection & Testing: API 598

TEST PRESSURE		
Testing	Body	Seat
Hydraulic	15 Kg / Cm ²	10 Kg / Cm ²

Drawing >>

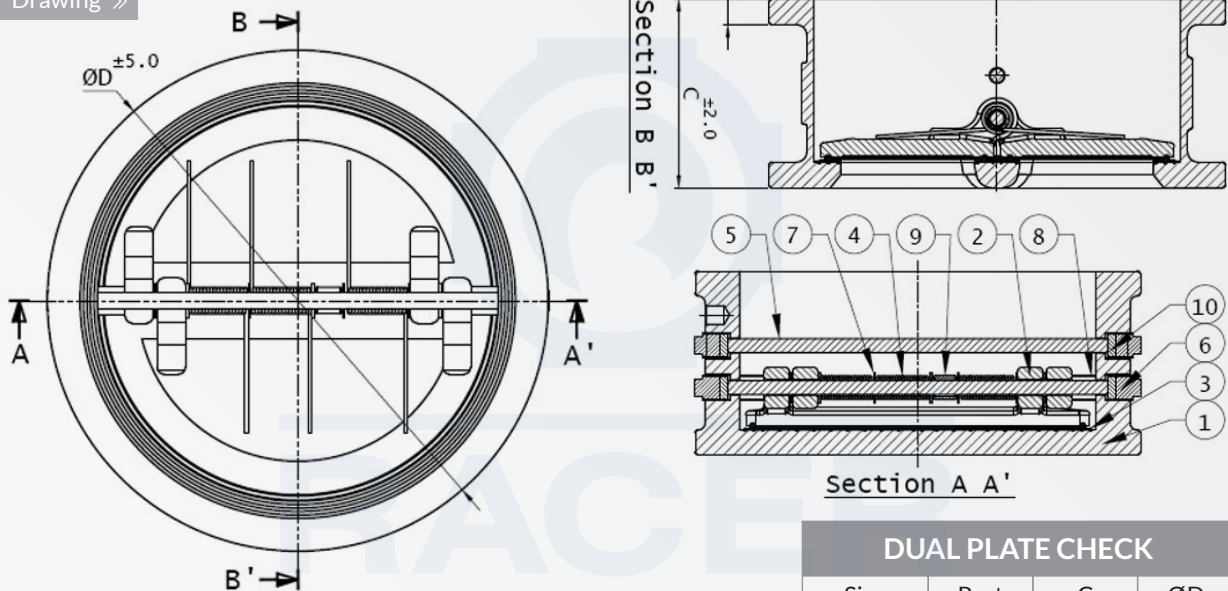

S. N.	Parts Name	Material
01	Packing Washer	NBR (ASTM D 3187 Grade NBR)
02	Space Bush	SS 304 (ASTM A 276 Type 304)
03	Space Bush	MS (ASTM A 350 Class LF1)
04	Space Washer	SS 304 (ASTM A 276 Type 304)
05	Pin Lock Nut	MS (ASTM A 350 Class LF1)
06	Stop Pin & Hinge Pin	SS 304 (ASTM A 276 Type 304)
07	Spring	Spring Steel
08	Seat	NBR (ASTM D 3187 Grade NBR)
09	Plate	ASTM A 351 Gr. CF 8M
		ASTM A 351 Gr. CF 8
		ASTM A 216 Gr. W.C.B.
10	Body	IS 210 Gr. FG 220
		ASTM A 216 Gr. W.C.B.

DUAL PLATE CHECK			
Size	Port	C	ØD
50	-	60	105
65	-	67	124
80	-	73	137
100	-	73	175
125	-	86	197
150	-	98	222
200	-	127	279
250	273	146	340
300	300	181	410
350	350	184	445
400	400	191	510
450	450	203	545
500	500	219	600
600	600	222	712

Note: (1) All Dimension are in mm
 (2) Tolerance ± 3 mm

Application

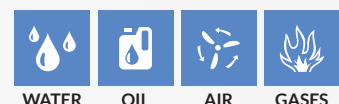

I. C. "Y" Strainer Screw End

Technical Data

Face to Face: As Per "Y" Type
 End Connections: Screw End to BSP
 Socket Weld Ends to: ANSI B 16.11



Drawing »

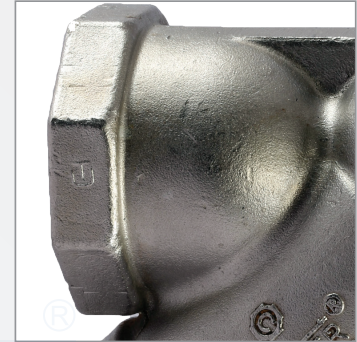
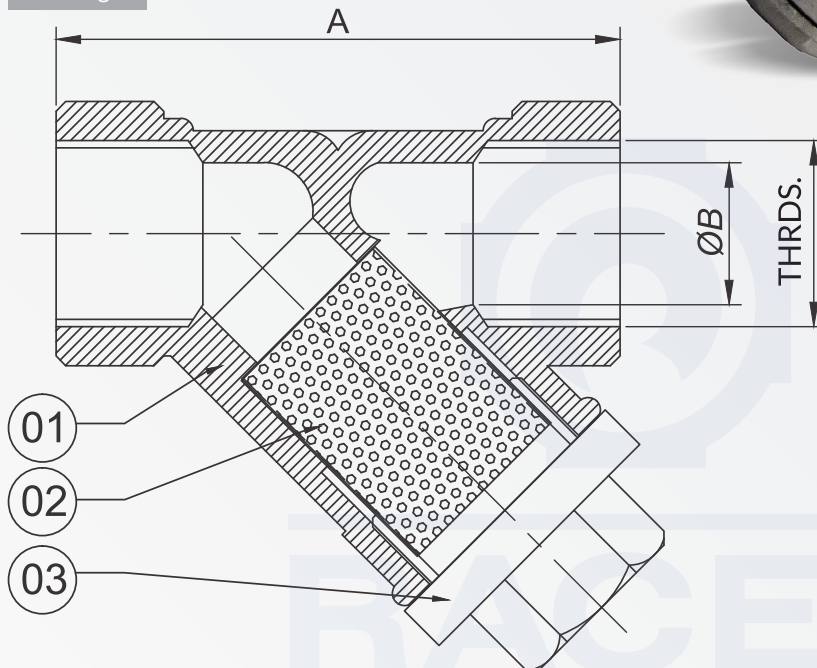

S. N.	Parts Name	Material	Qty
01	Body	ASTM A 351 Gr. CF8/CF8M	1
02	Screen	M.S./S.S. 202/304/316	1
03	Cover	ASTM A 351 Gr. CF8/CF8M	1

PRIMARY SERVICE RATING & TEST PRESSURE

Class	Hydro Test Pressure		Max. Temp.
	Body		
150	425 PSI		180°C

"Y" STRAINER S/E

Size		A	ØB	THRDS. (BSP/NPT)
Inch	M.M.			
1/2"	15	58	13	1/2"
3/4"	20	73	19	3/4"
1"	25	90	25	1"
1.1/4"	32	92	32	1.1/4"
1.1/2"	40	111	38	1.1/2"
2"	50	123	50	2"

Note: (1) All Dimension are in mm
 (2) Tolerance ± 3 mm

I. C. "Y" Strainer Flange End

Technical Data

Face To Face:	As Per DIN-40 Type / ANSI B 16.10
End Connections:	Flange as per ANSI B 16.5
Shell Wall Thickness:	ANSI B 16.34



Drawing »

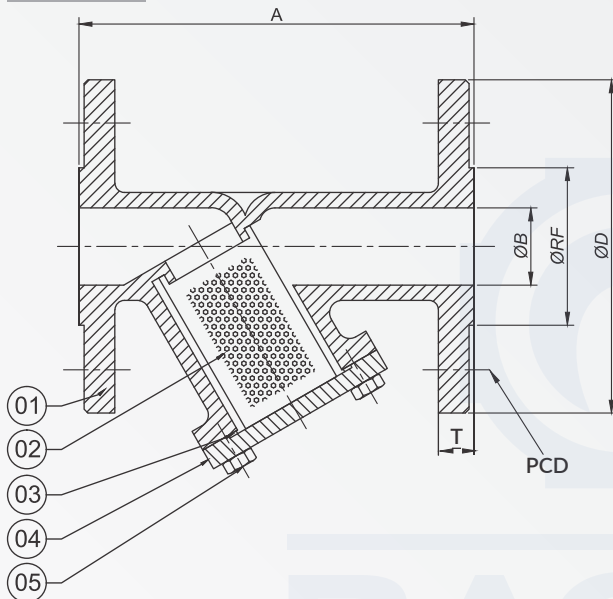

S. N.	Parts Name	Material	Qty
01	Body	ASTM A 351 Gr. CF8/CF8M	1
02	Screen	304/316	1
03	'O' Ring	PTFE	1
04	Cover	ASTM A 351 Gr. CF8/CF8M	1
05	Cover Nut Boltst	M.S./S.S.	-

"Y" STRAINER F/E						
Size	A	ØB	ØD	RF	PCD	T
25	127	25	108	51	79.5	11.5
40	165	38	127	73	98.5	13
50	178	50	152	95	118	14.5
65	189	64	176	105	138	14.5
80	202	75	189	126	151	16
100	232	100	225	157	190.5	17
125	356	126	254	185	216	22
150	410	152	277	216	241	26.5

PRIMARY SERVICE RATING & TEST PRESSURE		
Class	Hydro Test Pressure	Max. Temp.
	Body	
150	425 PSI	180°C

Note: (1) All Dimension are in mm
(2) Tolerance ± 3 mm

C. I. "Y" Strainer Screw End

Technical Data

Face To Face: As per Mfr's Std.
End Connections: Screw End To BSP

Drawing »

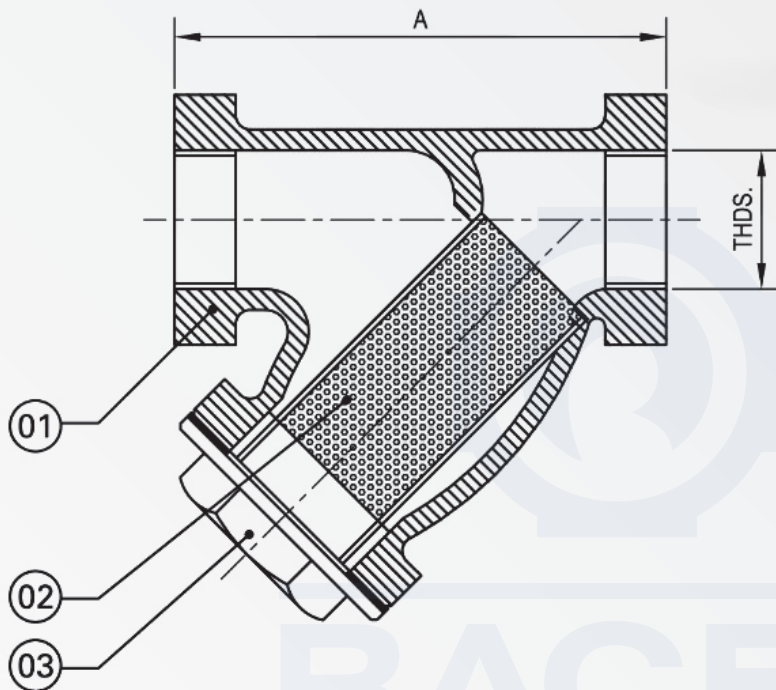

"Y" STRAINER FALGED END.

Size	THDS.	A
15	1/2" B.S.P. THD.	99
20	3/4" B.S.P. THD.	104
25	1" B.S.P. THD.	120
40	1.1/2" B.S.P. THD.	144
50	2" B.S.P. THD.	157
65	2.1/2" B.S.P. THD.	208
80	3" B.S.P. THD.	235
100	4" B.S.P. THD.	281

Hydraulic Test Pressure

Body 7 Kg/cm²

S. N.	Parts Name	Material	Qty
01	Body	C.I.	1
02	Screen	S.S. 202/S.S. 304	1
03	Cover/Bush	C.I.	1

Note: (1) All Dimension are in mm
(2) Tolerance ± 3 mm

C.I. "Y" Strainer Flange End

Technical Data

Face To Face: As per Mfr's Std.
End Connections: Flange as per ANSI B 16.5

Drawing »

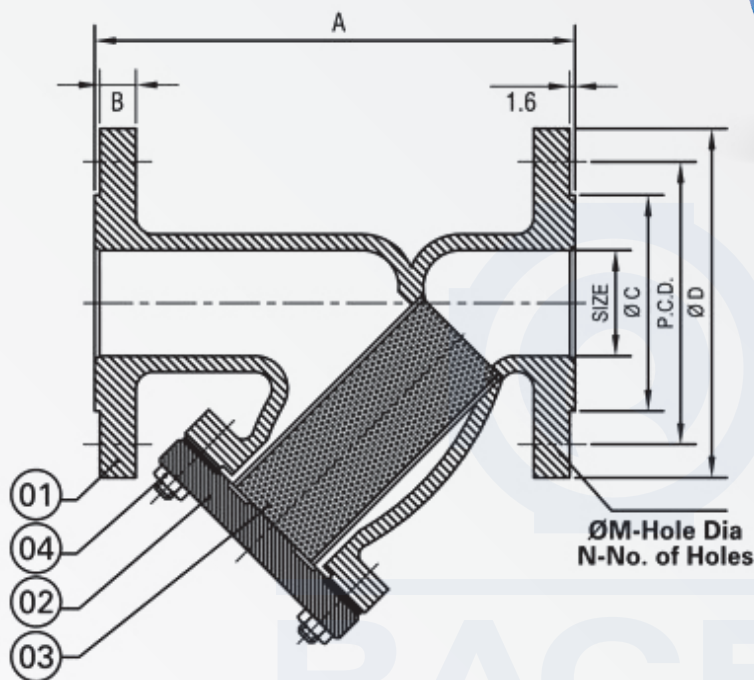

CLASS 150#

Size	A	B	ØC	ØD	ØM	P.C.D.
25	174	11	51	108	16	79
40	202	14	73	127	16	98.5
50	210	16	92	152	19	120.5
65	220	17.5	105	178	19	140
80	242	19	127	190.5	19	152.4
100	294	24	157	229	22	190.5
150	383	25	216	279	22	241
200	454	28.5	270	343	22	298.4
250	564	30	324	406	25	362
300	630	30	382	483	25	432

Hydraulic Test Pressure

Body	
7 Kg/cm ²	100 PSIG

S. N.	Parts Name	Material	Qty
01	Body	C.I.	1
02	Cover	C.I.	1
03	Screen	S.S. 202/S.S. 304	1
04	Cover Stud & Nut	M.S.	-

Note: (1) All Dimension are in mm
(2) Tolerance ± 3 mm

C. S. "Y" Strainer Flange End

Technical Data

Face To Face:	As per DIN ND-40 Type/ANSI B 16.10
End Connections:	Flange as per ANSI B 16.5
Shell Wall Thickness:	ANSI B 16.34

Drawing »

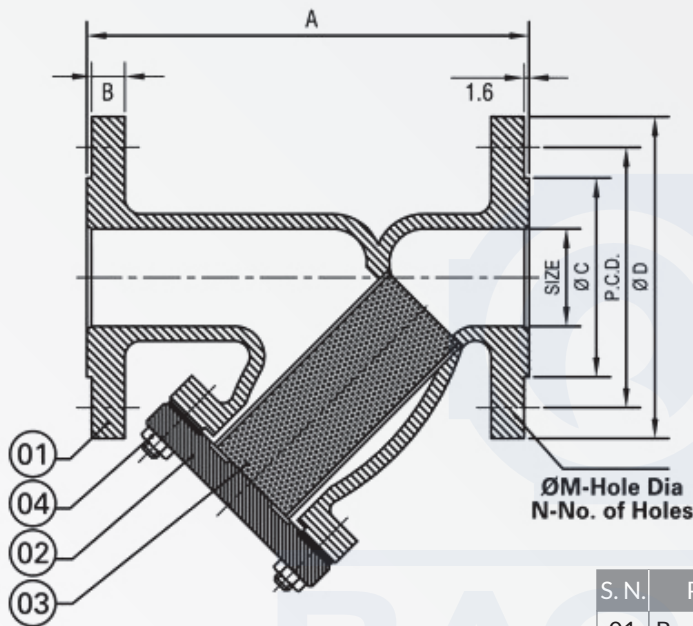

Hydraulic Test Pressure	
Body	10 Kg/cm ²

S. N.	Parts Name	Material	Qty
01	Body	ASTM A 216 Gr. WCB	1
02	Cover	ASTM A 216 Gr. WCB	1
03	Screen	S.S./304	1
04	Cover Stud & Nut	M.S.	-

CLASS 150#							
Size	A	B	ØC	ØD	ØM	N	P.C.D.
25	127	11	51	108	16	4	79
40	165	14	73	127	16	4	98.5
50	203	16	92	152	19	4	120.5
65	216	17.5	105	178	19	4	140
80	241	19	127	190.5	19	4	152.4
100	292	24	157	229	22	8	190.5
150	406	25	216	279	22	8	241
200	495	28.5	270	343	22	8	298.4
250	622	30	324	406	25	12	362
300	698	30	382	483	25	12	432

ND - 40							
Size	A	B	ØC	ØD	ØM	N	P.C.D.
25	160	18	68	115	14	4	85
40	200	18	88	150	18	4	110
50	230	20	102	165	18	4	125
65	290	22	122	185	18	8	145
80	310	24	138	200	18	8	160
100	350	24	162	235	23	8	190
150	480	28	218	300	27	8	250
200	600	35	285	375	30	12	320
250	730	38	345	450	30	12	385

Note: (1) All Dimension are in mm
(2) Tolerance ± 3 mm



T / Basket / Bucket Type Strainer Flange End (Fabricated)

Technical Data

Design and Manufacturing Std: As per Mfr's Std.
 End Connection: Flanged as per ANSI B 16.5-150#
 Shell Wall Thickness: As Per Pipe Standard
 Face to Face: As Per ANSI / B 16.10 Shown

Drawing »

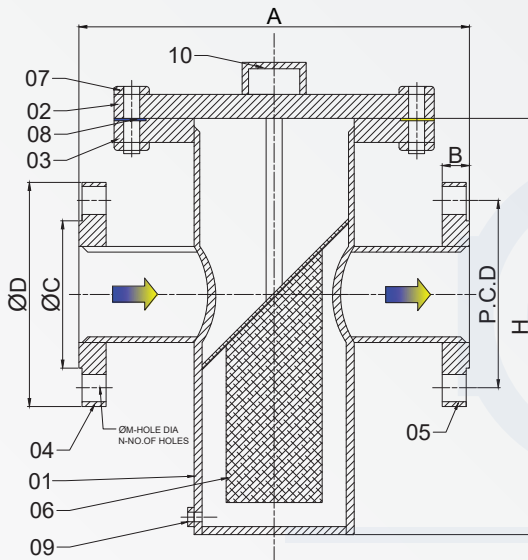

Hydraulic Test Pressure

Body
10 Kg/cm ²



S. N.	Parts Name	Material	Qty
01	Body	IS 2062	01
02	Top Cover	IS 2062	01
03	Body Cover	IS 2062	01
04	Inlet Flange	IS 2062	01
05	Outlet Flange	IS 2062	01
06	Screen	SS 304	01
07	Cover Bolt & Nut	Carbon Steel	Req
08	Gasket	Non Asbestos/ Graphoil	01
09	Drain Plug	ASTMA105	01
10	Lifting Handle	Carbon Steel	01

SIZE		CLASS 150#							
Inch	M.M.	A	H	B	ØC	ØD	ØM	N	P.C.D.
1"	25	200	300	11	51	108	16	4	79
1.1/2"	40	260	330	14	73	127	16	4	98.5
2"	50	260	335	16	92	152	19	4	120.5
2.1/2"	65	260	350	17.5	105	178	19	4	140
3"	80	300	365	19	127	190.5	19	4	152.5
4"	100	330	420	24	157	229	19	8	190.5
5"	125	400	455	24	186	255	22	8	216
6"	150	400	480	25	216	279	22	8	241
8"	200	465	620	28.5	270	343	22	8	298.4
10"	250	515	770	30	324	406	25	12	362
12"	300	575	940	32	381	483	25	12	432
14"	350	680	1040	35	412.7	533.4	28.6	12	476.2
16"	400	750	1085	36.5	469.9	596.9	28.6	16	539.2
18"	450	850	1200	40	533.4	635	31.7	16	577.8
20"	500	1000	1300	43	584.2	698.5	31.7	20	635.0
24"	600	1200	1400	47.6	692.1	812.8	34.9	20	749.3

Note: (1) All Dimension are in mm
 (2) Tolerance ± 3 mm

Application



IC Full View Sight Glass

Technical Data

Face To Face: As per Standard Length
End Connections: Flange Ends

Drawing »

ØM-Hole DIA
N-No. Of Hole
PCD Equispaced
off centred

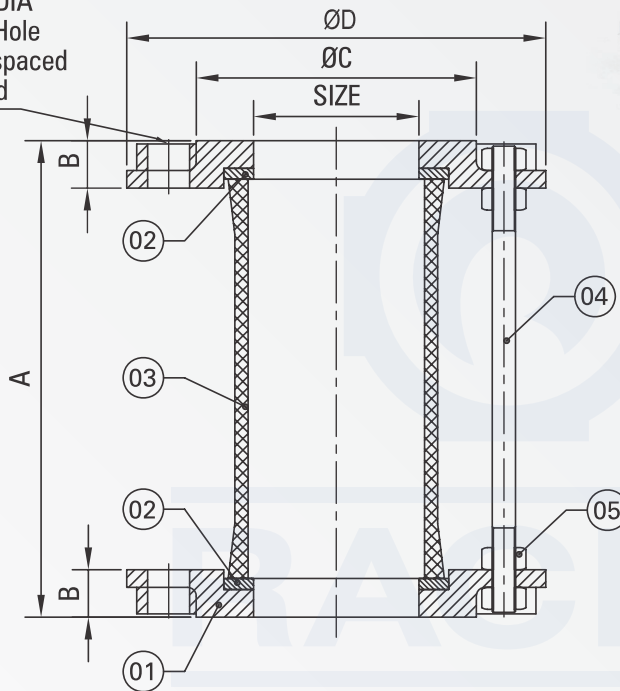

FULL VIEW SIGHT GLASS 150#								
Size	A(6")	A(4")	B	ØC	ØD	ØM	N	PCD
15	170	121	16	35	87.5	13	4	59.5
20	170	121	16	42	97.5	13	4	70
25	177	125	19	49	106.5	15	4	78
40	181	130	19	70	125	16	4	96
50	183	131	20	89	151	19	4	119
65	183	132	20	104	178	19	4	139.5
80	180	132	20	123	188	19	4	149
100	188	133	23	154	227	19	4	188
150	198	148	26	215	280	23	8	240

S. N.	Parts Name	Material	Qty
01	Flange	CF8/CF8M	2
02	Gasket	PTFE	2
03	Glass Tube	Toughaned	1
04	Stud	S.S. 202/304/316	-
05	Nut	S.S. 202/304/316	-

Hydraulic Test Pressure

Body

5 Kg/cm²

Note: (1) All Dimension are in mm
(2) Tolerance ± 3 mm

Application



IC Double Window Sight Glass Flange End

Technical Data

Face To Face: As per Standard Length

End Connections: Flange End

Drawing »

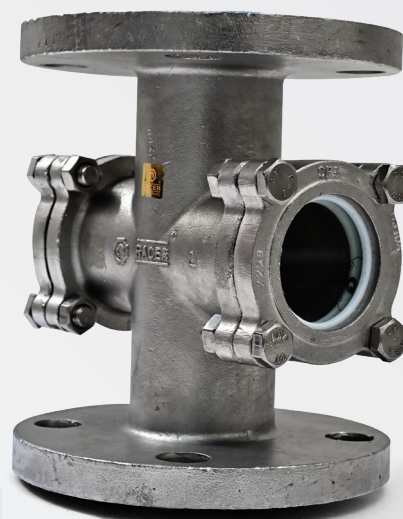
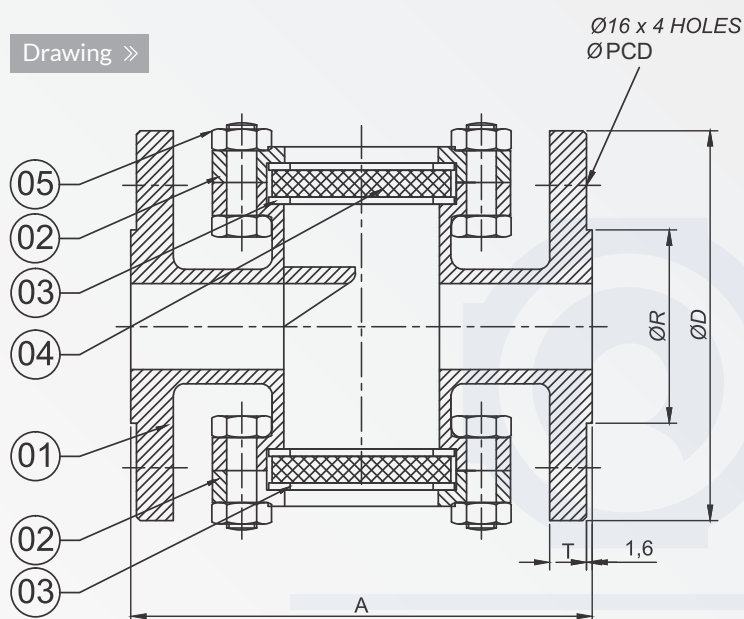

DOUBLE WINDOW SIGHT GLASS 150#

Size	A	ØD	PCD	ØR	ØM	N	T
25	127	108	79	51	16	4	12
40	165	127	97	73	16	4	14.5
50	178	152.5	120	92	19	4	16.5
80	203	190	152	127	19	4	17
100	229	229	190.5	157	19	8	23

Hydraulic Test Pressure

Body

5 Kg/cm²

S. N.	Parts Name	Material	Qty
01	Body	CF8 (S.S. 304)/CF8M (S.S. 316)/WCB	1
02	Top & Bottom Flange	CF8 (S.S. 304)/CF8M (S.S. 316)/WCB	2
03	Seat O Ring	PTFE	2+2
04	Glass	Toughened Borosilicate	2
05	Studs & Nut	M.S./S.S./202/304/316	-

Note: (1) All Dimension are in mm
(2) Tolerance ± 3 mm

Application

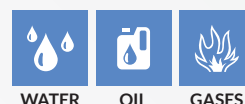

Full View Sight Glass Barstock Type

(M.S./S.S.)

Drawing »

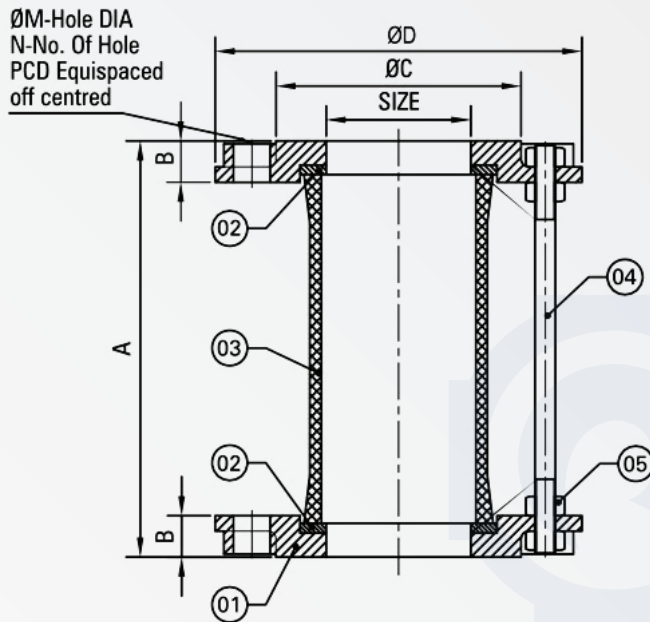

FULL VIEW SIGHT GLASS									
Size	A (6")	A (4")	B	ØC	ØD	ØM	N	PCD	Check Nut Type
15	170	120	12.5	35	89	16	4	60.3	-
20	170	120	12.5	43	98	16	4	69.8	-
25	172	122	13.5	51	108	16	4	79.4	188
40	175	125	15.5	73	127	16	4	98.4	188
50	177	127	16.5	92	152.4	19	4	120.5	188
65	182	132	18.5	105	178	19	4	139.7	192
80	182	132	18.5	127	190.5	19	4	152.4	192
100	182	132	18.5	157	230	19	8	190.5	192
150	186	136	22	216	279.5	22	8	241.5	192

S. N.	Parts Name	Material	Qty
01	Flange	S.S. 316/S.S. 304/M.S.	2
02	Gasket	PTFE	2
03	Glass Tube	Toughened	1
04	Stud	Zinc Plated Steel/S.S. 304	-
05	Nut	Zinc Plated Steel/S.S. 304	-

Note: (1) All Dimension are in mm
 (2) Tolerance ± 3 mm
 (3) Allen Key Type and
 Check Nut Type Desing available

Application



Gauge Glass Cock Set S/E & Gauge Glass Cock Set F/E

Technical Data

Design and Manufacturing Std: As per Mfr's Std.
 Testing and Inspection Std: BS5146
 End Connection: Screw BSP
 End Connection: Flange as per 150# & Table 'E'

Drawing »

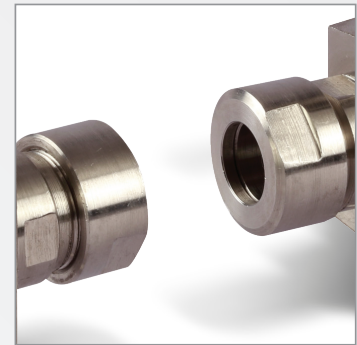
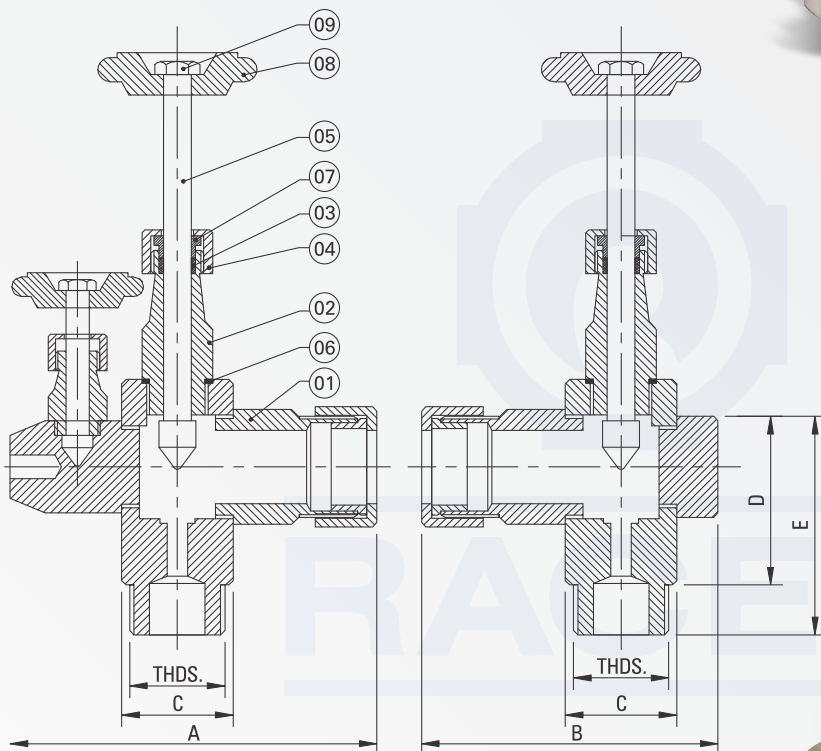

GAUGE GLASS S/E						
Size NB	A	THDS-BSP	B	C	D	E
15	101	1/2"	75	27	50	65
20	110	3/4"	80	31	55	70
25	135	1"	100	36	36	80

PRIMARY SERVICE RATING & TEST PRESSURE		
Hydro Test Pressure		Max. Temp.
Body	Seat	
215 PSI	145 PSI	180°C

S. N.	Parts Name	Material	Qty
01	Body	S.S. 202/S.S. 304/S.S. 316	1
02	Bonnet	S.S. 202/S.S. 304/S.S. 316	1
03	Gland	S.S. 202/S.S. 304/S.S. 316	1
04	Gland Nut	S.S. 202/S.S. 304/S.S. 316	1
05	Stem	S.S. 202/S.S. 304/S.S. 316	1
06	Body Gasket	PTFE	-
07	Gland Packing	PTFE	1
08	Hand Wheel	Bakelite	1
09	Hand Wheel Nut	M.S.	1

Note: (1) All Dimension are in mm
 (2) Tolerance ± 3 mm
 (3) Flange End Gauge glass available on request

Needle Valves

Technical Data

Design and Manufacturing Std: As per Mfr's Std.

Testing and Inspection Std: BS5146

End Connection: Screwed BSP



Drawing »

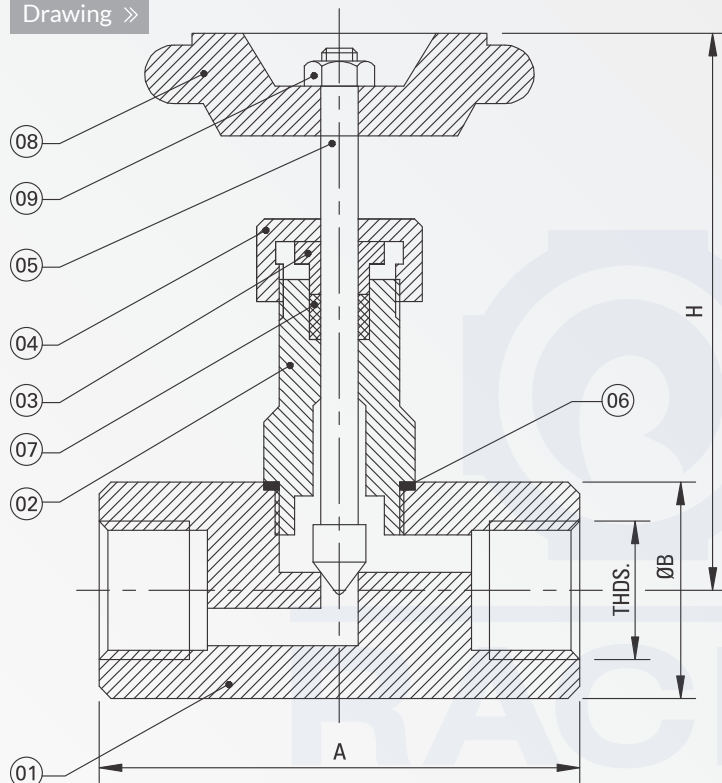

NEEDLE VALVE				
Size NB	A	THDS-BSP	H	ØB
8/10	50	1/4" - 3/8"	70	27
15	50	1/2"	70	31
20	63	3/4"	90	39
25	70	1"	95	45
40	85	1.1/2"	120	65
50	90	2"	130	75

PRIMARY SERVICE RATING & TEST PRESSURE	
Hydro Test Pressure	
Round Body	Square Body
1000 PSI	3000 PSI

S. N.	Parts Name	Material	Qty
01	Body	S.S. 202/S.S. 304/S.S. 316	1
02	Bonnet	S.S. 202/S.S. 304/S.S. 316	1
03	Gland	S.S. 202/S.S. 304/S.S. 316	1
04	Gland Nut	S.S. 202/S.S. 304/S.S. 316	1
05	Stem	S.S. 202/S.S. 304/S.S. 316	1
06	Body Gasket	PTFE	-
07	Gland Packing	PTFE	1
08	Hand Wheel	Bakelite	1
09	Hand Wheel Nut	M.S.	1

Note: (1) All Dimension are in mm
 (2) Tolerance ± 3 mm
 (3) 6000 PSI and 10000 PSI available on request



I. C. Steam Traps

Technical Data

End Connection: Screw End / BSP

Drawing »

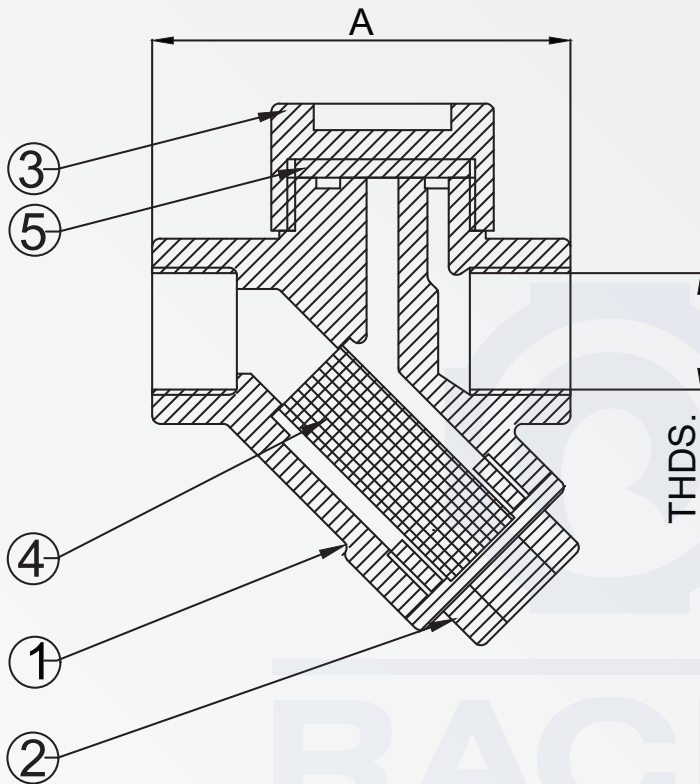

STEAM TRAP			
Size		A	THRDS. (BSP\NPT)
Inch	M.M.		
1/2"	15	79	1/2"
3/4"	20	79	3/4"
1"	25	88	1"

S. N.	Parts Name	Material	Qty
01	Body	AISI 410	1
02	Cap	AISI 410	1
03	Body Cover	AISI 410	1
04	Screen	SS	1
05	Disc	AISI 410	1

Note: (1) All Dimension are in mm
(2) Tolerance ± 3 mm

C. I. Bucket & Ball Float Type Steam Traps

Technical Data

Design and Manufacturing Std: IS 12268 / ISO 6552

End Connection: Screw End, BSP

Body Test: 15 Kg / Cm²

Drawing »

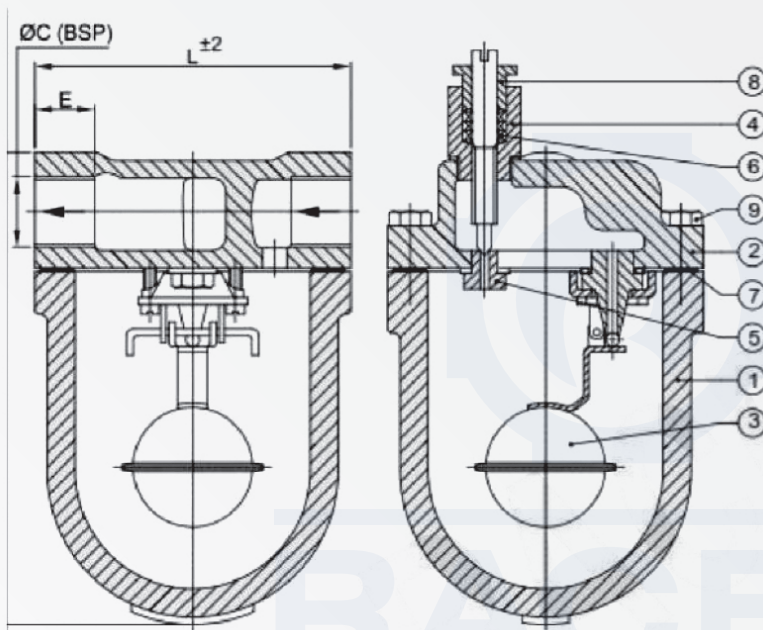

STEAM TRAP			
Size		L	ØC (BSP)
Inch	M.M.		
1"	25	124 mm	1"
1.5"	40	270 mm	1.5"
2"	50	270 mm	2"

S. N.	Parts Name	Material
01	Body	CI to IS 210 Gr. FG 200
02	Cover	CI to IS 210 Gr. FG 200
03	Bucket	S.S.
04	Valve	Gun Metal
05	Lock Plate	S.S.
06	Cover Gasket	Graphite
07	Seat	S.S.
08	Body Bolt & Nut	Carbon Steel
09	Cover Bolt	Carbon Steel

Note: (1) All Dimension are in mm
(2) Tolerance ± 3 mm

Knife Edge Gate Valves

Drawing »

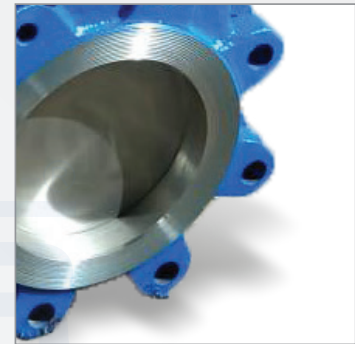
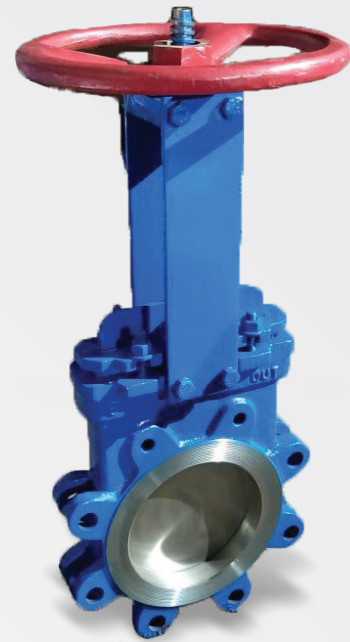
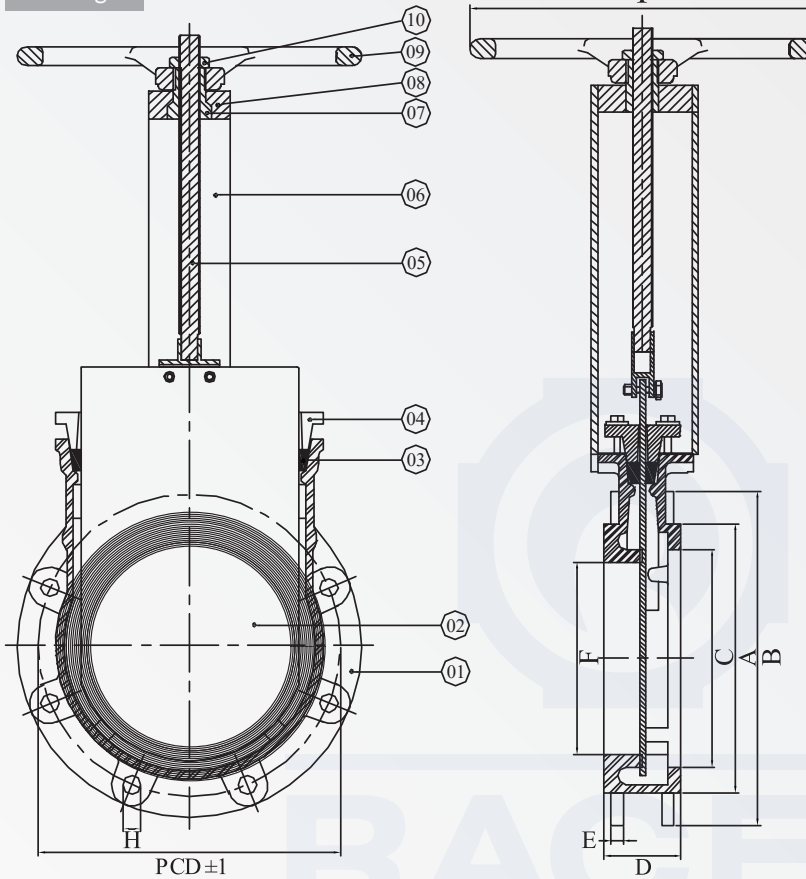

KNIFE EDGE GATE VALVE

Size NB	A	B	C	D	E	F	H	I	PCD
2" 50	95	150	60	50	12	50	14	200	121
2.5" 65	110	170	70	50	12	65	14	200	140
3" 80	120	180	80	50	12	75	14	200	153
4" 100	155	225	115	56	12	100	18	205	191
5" 125	185	245	135	56	15	125	18	205	216
6" 150	200	275	160	60	15	150	18	260	243
8" 200	260	340	215	70	16	200	18	320	299
10" 250	330	406	260	70	16	250	20	320	362
12" 300	360	474	310	70	16	300	20	360	432
14" 350	440	530	365	75	18	350	22	360	476
16" 400	488	590	410	90	18	400	25	450	540

S. N.	Parts Name	Material	Qty
01	Body	WCB/SS 304/316	01
02	Gate	SS 304	01
03	Gland Packing	Imp. Asbestos	01
04	Gland Busher	S.G.I.	01
05	Spindle	SS 304	01
06	York	M.S./S.S.	01
07	Sleeve	G.M.	01
08	Block	CI	01
09	Wheel	SGI	01
10	Fastners	MS	01

Note: (1) All Dimension are in mm
(2) Tolerance ± 3 mm

C. I. Foot Valves Flange End 150#

Technical Data

Design and Manufacturing Std: Generally Conforming to IS 4038/BS-1

End Connection: BS 4504 (PN-16)

Drawing »

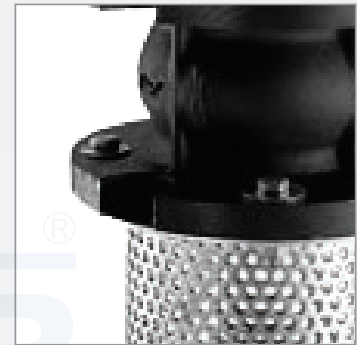
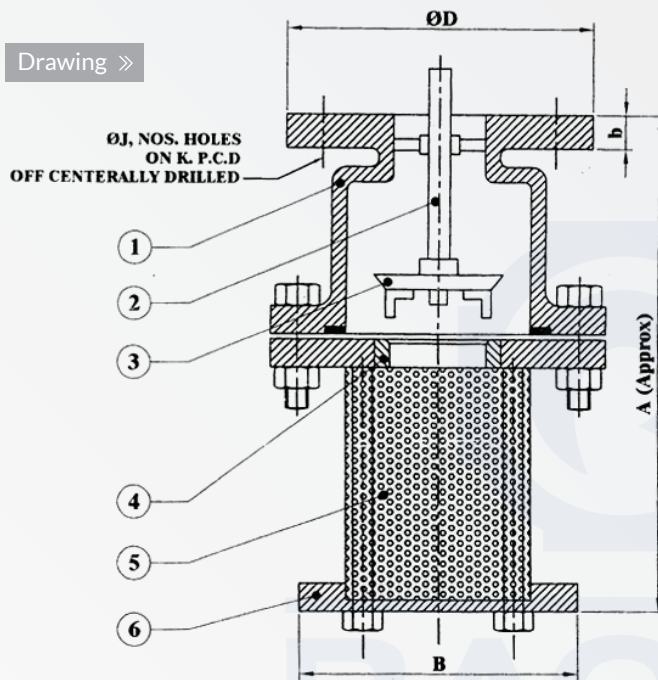

C. I. FOOT VALVE FE 150#							
Size	A	B	ØD	b	ØJ	N	K P.C.D.
40	-	-	133.3	16	4	19	-
50	180	100	152.4	18	4	19	114.3
65	187	115	165.1	18	4	19	127
80	210	136	184.1	21	4	19	146
100	245	165	216	22	4	19	177.8
125	273	207	254	22.5	8	19	209.5
150	320	223	279.4	23	8	23	235
200	400	280	336.5	24.5	8	23	292
250	485	320	406.4	26	8	23	355.6
300	555	378	457.2	27.5	12	23	406.4
350	660.5	495.3	527	28	12	23	470
400	673.1	558.8	577.8	30	12	28	520.7
450	735	605	641.3	31.5	12	28	584.2
500	840	665	704.8	33	16	28	641.3

S. N.	Parts Name	Material	Qty
01	Body	BS 1452 GR 220	01
02	Valve Guide	Brass/MS/S.S.	01
03	Valve	G.M. BS 1400 LG 2	01
04	Seat	G.M. BS 1400 LG 2	01
05	Screen	Galvanized Iron	01
06	Plate	BS 1452 GR 220	01

TEST PRESSURE

Testing	Body	Seat
Hydraulic	215 PSI	140 PSI

Note: (1) All Dimension are in mm
(2) Tolerance ± 3 mm

P.P. Ball Valves Flange End



Drawing »

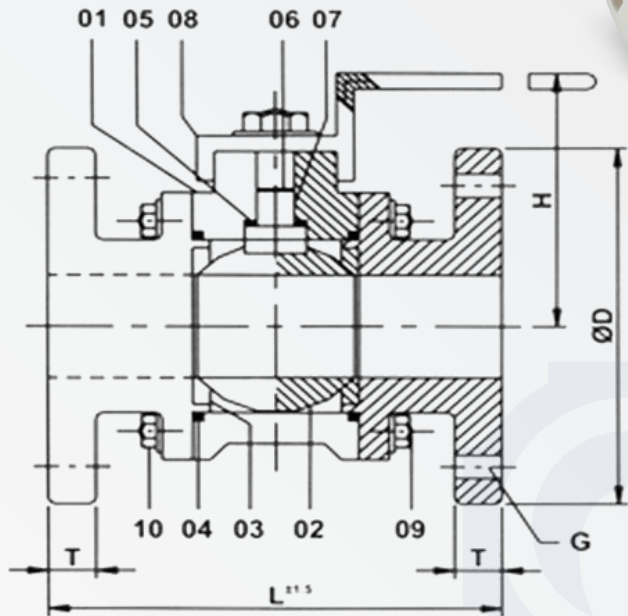

PP BALL VALVE F/E ($\pm 3\text{MM}$)					S. N.	Parts Name	Material
Size NB	D	T	L	H	01	Body	Polypropoline
1"	120	18	150	88	02	Ball	Polypropoline
1.1/2"	140	20	172	110	03	Seal Ring	PTFE
2"	168	22	200	118	04	Packing Ring	Neoprene
2.1/2"	185	25	235	150	05	Steam Seal Ring	PTFE
3"	200	25	250	160	06	'O' Ring	Neoprene
4"	230	28	300	185	07	Stem	M.S. with P.P Coating
6"	300	32	425	235	08	Handle	M.S. with P.P Coating
1/2"	95	15	130	65	09	Hex Nut Washer	M.S. Zinc Plated
3/4"	100	16	148	75	10	Nexnut Washer	M.S. Zinc Plated

Note: (1) All Dimension are in mm
 (2) Tolerance ± 3 mm
 (3) Screw End available on request

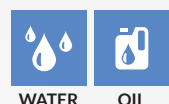

P.P. Foot Valves Flange End

Drawing »

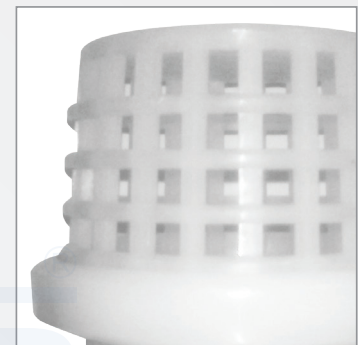
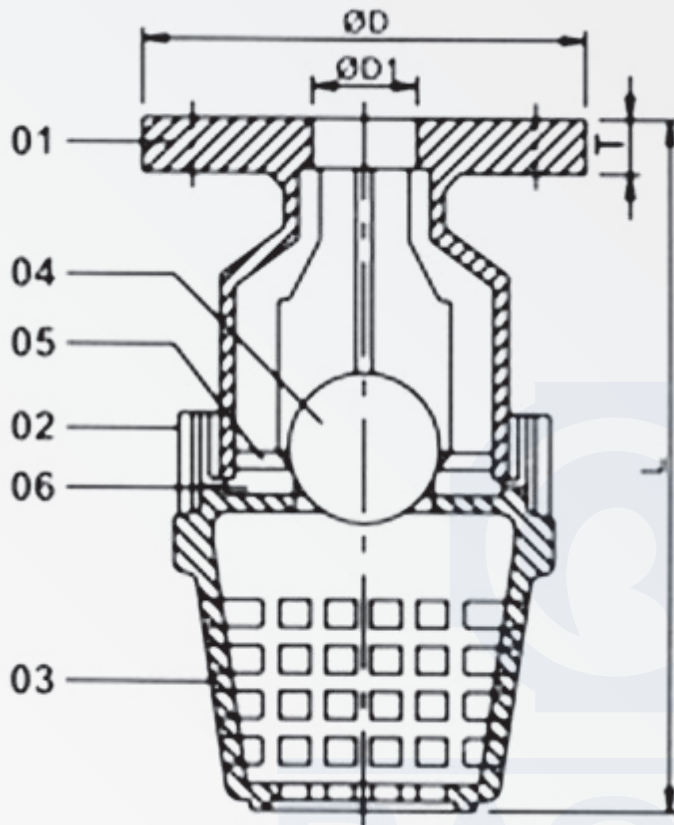

PP FOOT VALVE FE ($\pm 2\text{MM}$)					
Size		D	D1	L	T
IN	MM				
1"	25	120.0	26.0	170	18.0
1.1/2"	40	140.0	38.0	200	21.0
2"	50	160.0	54.0	210	23.0
2.1/2"	65	182.0	64.0	295	25.0
3"	80	200.0	77.0	295	26.0
4"	100	229.0	100.0	370	26.0

S. N.	Parts Name	Material
01	Top Body	Polypropylene
02	Bottom Body	Polypropylene
03	Strainer	Polypropylene
04	Ball	Polypropylene
05	Stop Ring	Polypropylene
06	Seat Ring	Neoprene/EPDM/VITON/PTFE

Note: (1) All Dimension are in mm
(2) Tolerance ± 3 mm
(3) 6" valves available on request

P.P. NRV Flange End

Drawing »

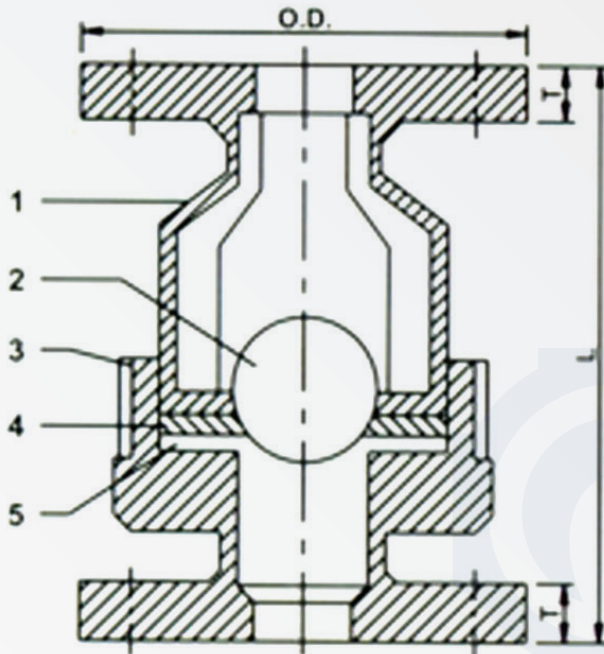

PP NRV FE (± 2 MM)				
Size		L ± 3	OD	T
IN	MM			
1"	25	136	118	17
1.1/2"	40	166	141	18
2"	50	177	160	21
2.1/2"	65	255	183	25
3"	80	255	200	25
4"	100	330	230	27
6"	150	345	295	30

S. N.	Parts Name	Material
01	Body	Polypropylene
02	Solid Ball	Polypropylene
03	Seat Pad	Polypropylene
04	Seat	Neoprene/EPDM/Viton/PTFE
05	Stop Ring	Polypropylene

Note: (1) All Dimension are in mm
(2) Tolerance ± 3 mm

Other Products

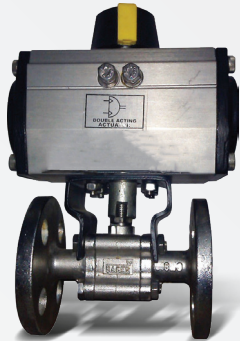

IC Actuator Ball Valve
MOC: CF8 / CF8M
Range: 15mm to 200mm

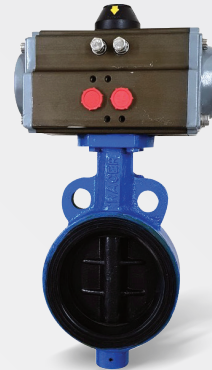

Butterfly Valve with Actuator
MOC: C.I. / C.S. / S.S
Range: 40mm to 300mm



C.S. Ball Valves Fe With Actuator
Range: 15mm to 200mm



Butterfly Valve (Lug Tpe)
MOC: C.I. / C.S. / S.S.
Range: 40mm to 300mm



Butterfly (Double Flanged Type)
MOC: C.I. / C.S. / S.S.
Range: 40mm to 300mm

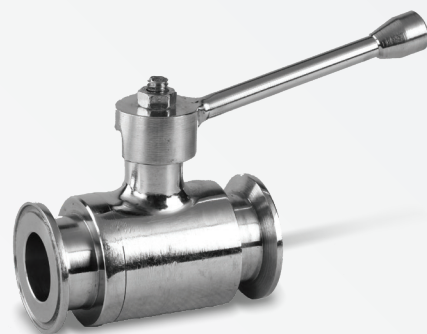

Barstock Tri Clover End Ball Valve
MOC: SS 304 / 316
Range: 15mm to 50mm

Other Products



FS Lift Up Check Valve Screw End
Range: 15mm to 50mm



Horizontal NRV Screw End
MOC: SS 202 / 304 / 316
Range: 15mm to 50mm



Vertical NRV Screw End
MOC: SS 202 / 304 / 316
Range: 15mm to 50mm



Flush Bottom Valve - 'Y' Type
MOC: M.S. / S.S. 304 / 316
Range: 25mm to 200mm



Piston Valve Flange End
MOC: C.S. / F.S.
Range: 25mm to 150mm

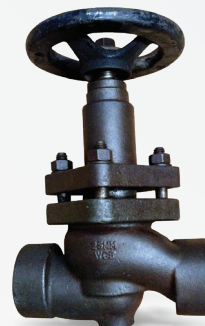

Piston Valve Screw End
MOC: C.S.
Range: 15mm to 50mm

Other Products



P.P. Foot Valve Screw End
Range: 15mm to 50mm

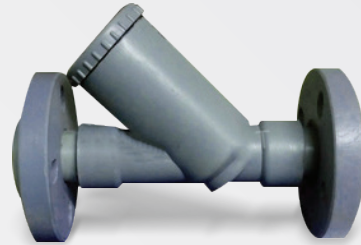

P.P. Y Strainer Flange End
Range: 15mm to 100mm

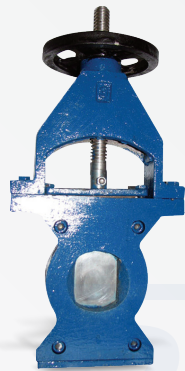

C. I. Pulp Valve
MOC: C.I.
Range: 50mm to 150mm

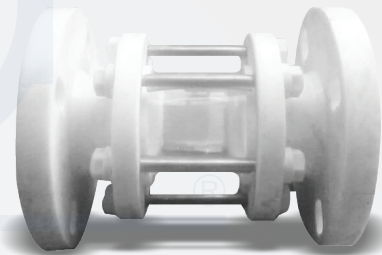

P. P. Sight Glass
Range: 25mm to 100mm



IC WCB 2PC F/E 150#
MOC: IC WCB
Range: 15mm to 150mm



Pot Type Strainer
MOC: M.S. (Fabricated)
Range: 25mm to 600mm

Certificates



Our Clients



Our Achievements



Proud Moment To Recived MSME Award
By Our Honorable CM Mr. Vijaybhai Rupani



Proud Moment To Recived
Honour From DIC



Proud Moment To Recived Excellence Award
By Our Honorable CM Mr. Bhupendrabhai Patel



RACER VALVES PVT. LTD.

Gujarat, India

 www.racervalves.com